

**LOSSAN** Los Angeles  
San Diego  
San Luis Obispo  
Coastal Rail Corridor  
San Diego Segment



# SD-LOSSAN Regional Rail Corridor Improvements Study Update

Del Mar City Council | May 3, 2021

# 1 Study Background

# Los Angeles – San Diego – San Luis Obispo (LOSSAN) Rail Corridor



- Nation's second busiest intercity rail corridor behind the Northeast Corridor (8 million riders annually)
- Approximately \$1 billion in goods carried
- San Diego Subdivision is the southernmost 60.1 miles in San Diego County
- Owned by NCTD and MTS
- Part of Strategic Rail Corridor Network (STRACNET)
- More than \$1 billion identified for capital improvements (mainly capacity)



# Expected Study Results

The study will result in:

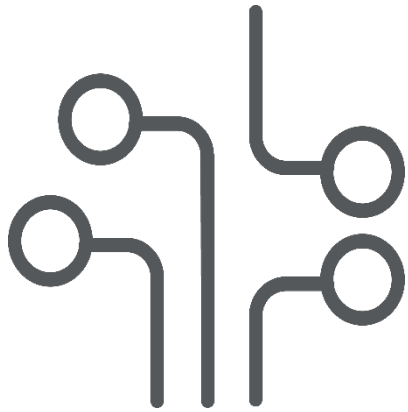

**Alternative Alignments**



**Proposed Improvements**

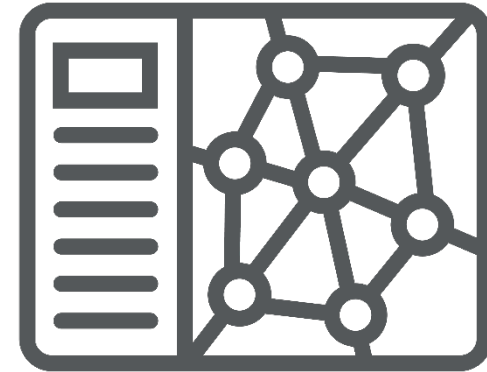

**Supporting Analysis for Passenger  
and Freight Rail Services**

**Consistent with the 5 Big Moves, recommended improvements will support future investments to reduce travel times, increase capacity, and enhance safety**

# Scope of Work

- Existing Conditions
- Corridor Resiliency
- Operational Feasibility –  
*Sorrento Mesa Branch Analysis*
- Basis of Design (Track)
- Basis of Design (Tunnel)
- Del Mar/Miramar Hill Alternatives Analysis
- Service Plans
- Corridor Wide Higher Speed Analysis
- Project Phasing/Implementation Plan
- Final Report

# Reporting Structure

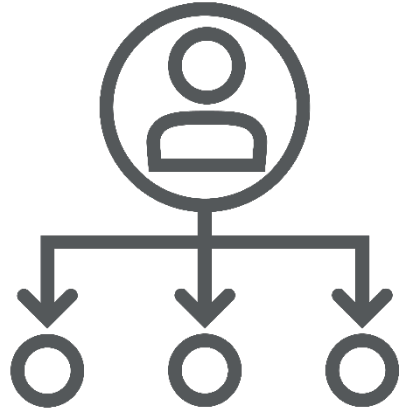

## PROJECT DEVELOPMENT TEAM

SANDAG  
NCTD  
MTS  
LOSSAN

Metrolink  
BNSF Railway  
FRA  
Caltrans

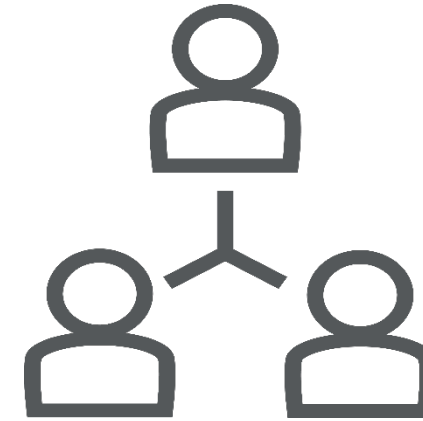

## EXECUTIVE LEADERSHIP TASK FORCE

## SANDAG BOARD OF DIRECTORS

# 2 Operational Feasibility

# Objectives

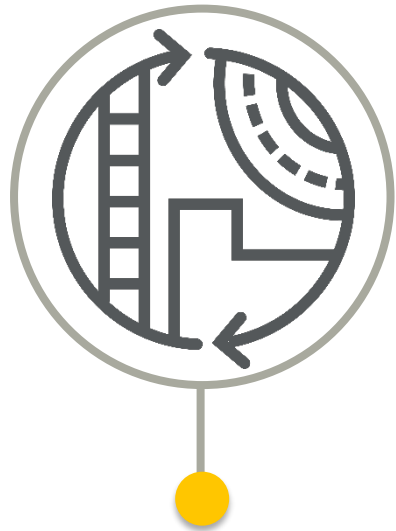

Evaluate technology, including higher speed diesel locomotives and electrification

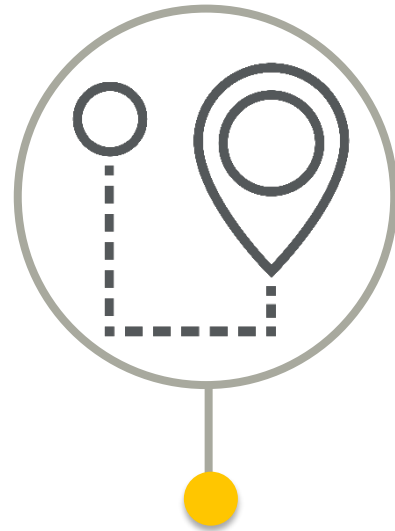

Identify freight and passenger service acceleration within context of LOSSAN Optimization Study



Assess changes to communications and signaling system and risks to current and near-term operations

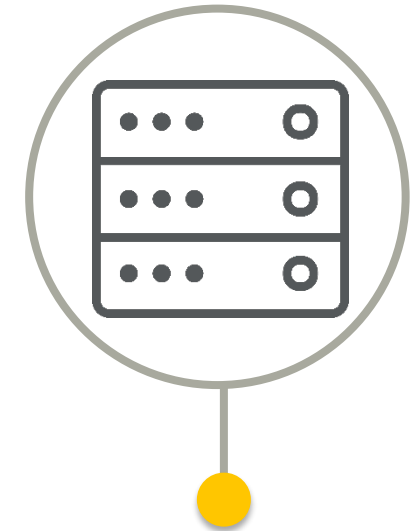

Test a planning-level service concept for future service to proposed Sorrento Mesa Mobility Hub (in coordination with South Bay to Sorrento CMCP)



# Infrastructure Assumptions

SANDAG's Infrastructure Development Plan<sup>1</sup>



## New stations at

- Del Mar Events platform
- UTC/Nobel Station
- San Diego International Airport

Double track rail corridor from the County Line to Downtown San Diego. The preliminary results assume Del Mar and Miramar Hill tunnels

Upgraded line speeds to support 110 mph operations

(1) Also recommended in the LOSSAN Optimization Study

# Equipment Tested

## NEW DIESEL



### Key Parameters

Speed  
[mph]

Siemens Charger

125

Pacific Surfliner (Limited Stop) service

110

COASTER (All Stop) service

90

Operating speeds are limited by trailer car design speeds

## ZERO EMISSIONS



### Key Parameters

Speed  
[mph]

Stadler KISS

110

# Equipment Performance



## Oceanside to San Diego

PRELIMINARY RESULTS

### All-stop service speed-distance diagram using Track Class 6 (110 mph)

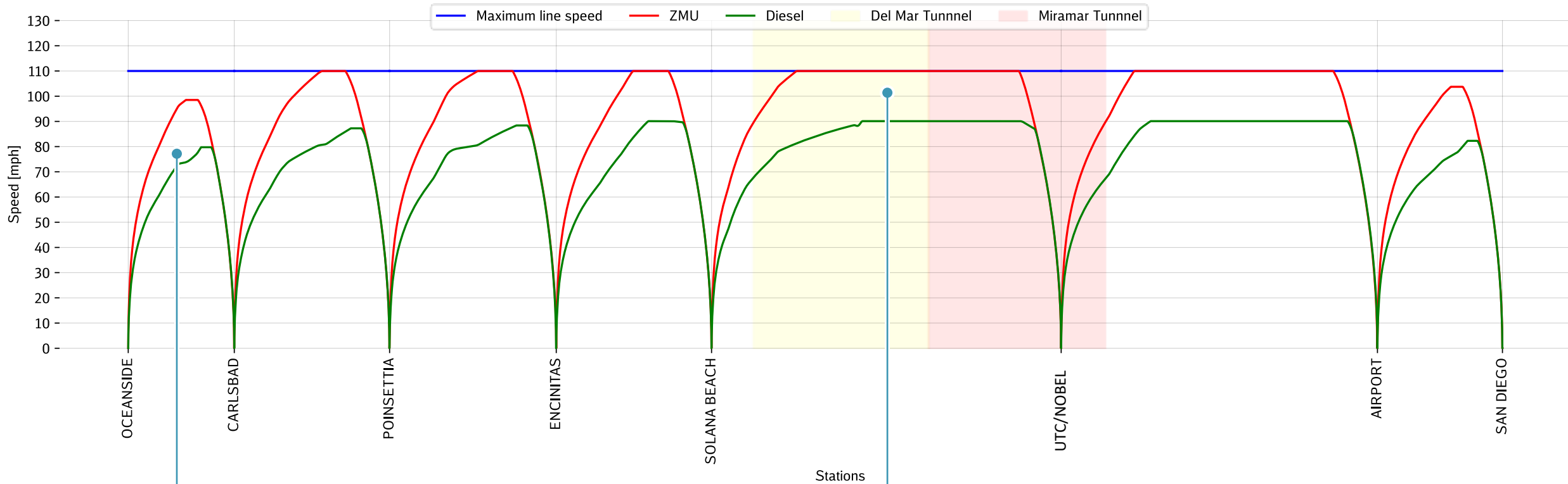

ZMU has better acceleration characteristics and performs better than diesel on gradients

ZMU can utilize maximum line speeds

# Preliminary Travel Time

(IN MINUTES)

## All-stop service: Oceanside – San Diego

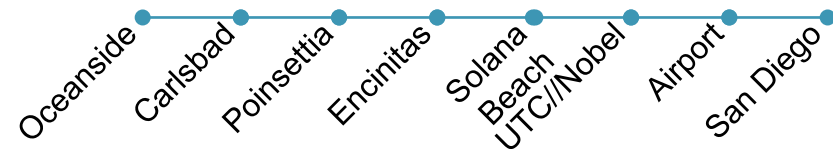

0 10 20 30 40 50 60

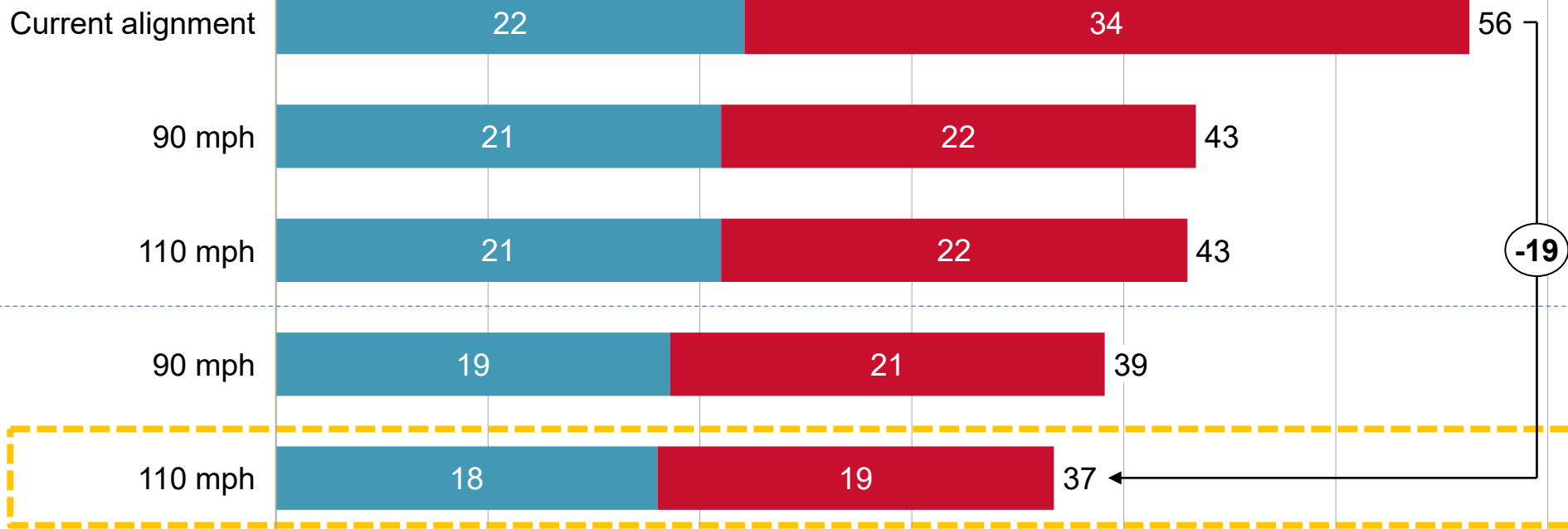

■ Oceanside - Solana Beach 
 ■ Solana Beach - San Diego



-19

# Preliminary Travel Time

(IN MINUTES)

## Limited-stop service: Oceanside – San Diego

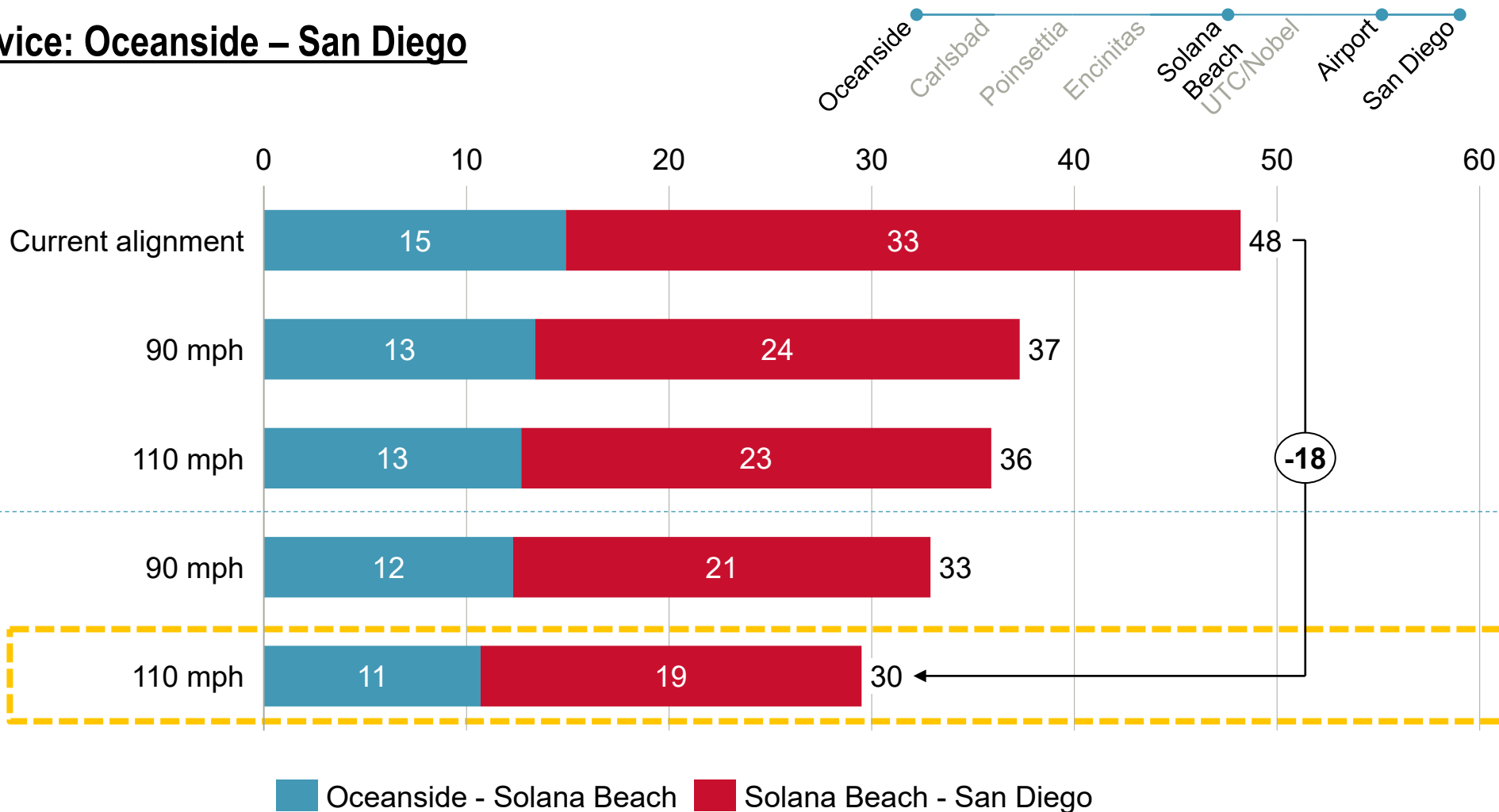

# Preliminary Operational Findings

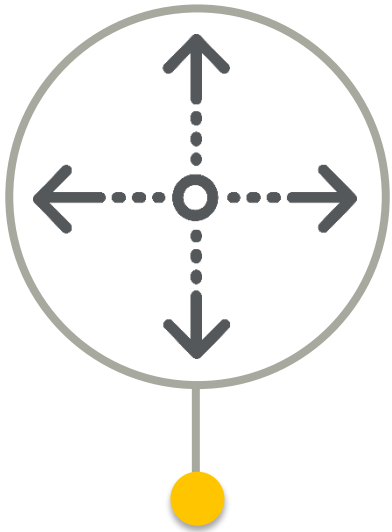

No measurable benefits for running 125 mph over 110mph due to station spacing



ZMU offers acceleration and braking benefits over diesel locomotive



Freight service safety concerns for running in shared corridor at more than 110 mph

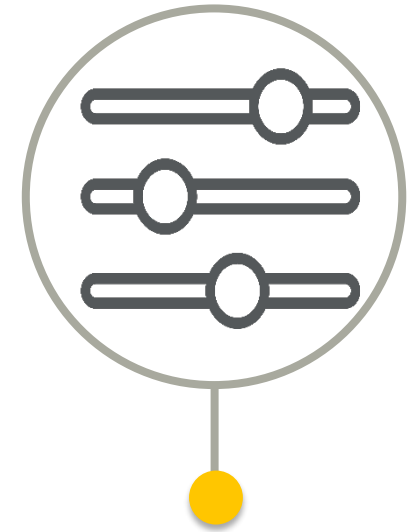

Speed improvements in SD County highlight critical infrastructure constraints at San Clemente

**Existing fleet cannot operate beyond 90 mph due to coach restrictions**

**3**

**Realignment**

**Alternatives Analysis**

# Del Mar Realignment

## REVISED ALTERNATIVES

- Camino Del Mar
- Crest Canyon Higher Speed
- Crest Canyon (Above/Below Carmel Valley Road)
- I-5
- ★ Proposed Portal

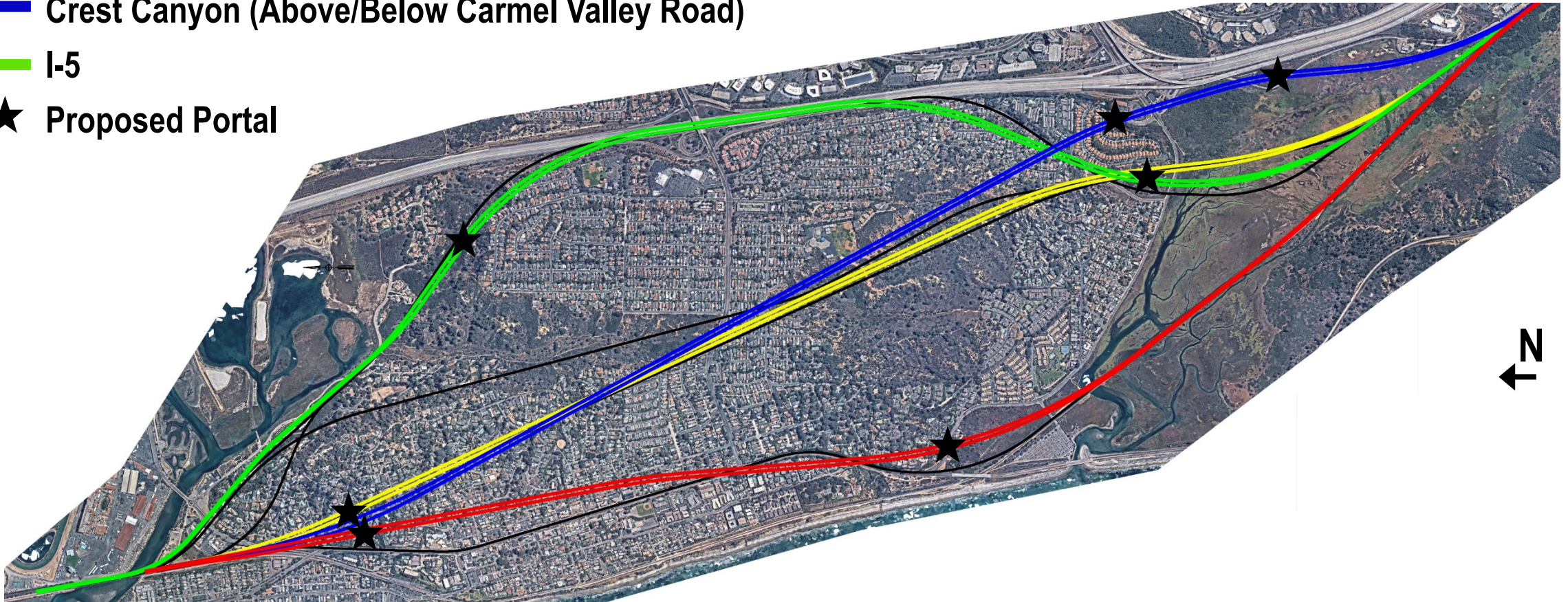



# Del Mar Realignment

## REVISED ALTERNATIVES

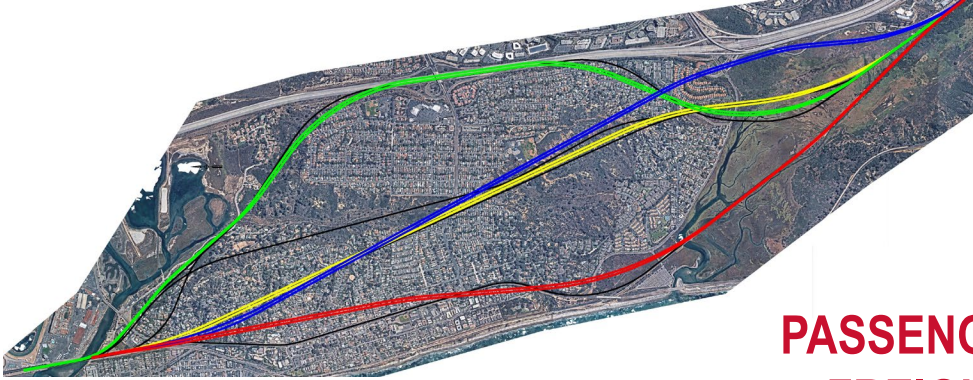

### ALIGNMENT

Today

■ Camino Del Mar

■ Crest Canyon Higher Speed

■ Crest Canyon (Above CVR)

■ Crest Canyon (Below CVR)

■ I-5

### PASSENGER/ FREIGHT MAX SPEED (MPH)

90/60

110/60

110/60

110/60

110/60

80/60

### CAPITAL COSTS COMPARISONS

-

Base

+5%

+5%

+10%

+30%

### TRAVEL TIMES (MINUTES) Solana Beach to Old Town

#### All Stop

#### Limited Stop

Charger + 5  
Coaches

ZMU

Charger + 7  
Coaches

ZMU

31

-

32

-

28.2

26.9

27.3

25.2

28.2

26.9

27.4

25.2

28.2

26.9

27.4

25.2

28.2

26.9

27.4

25.2

29.6

28.9

28.6

27.3

# Del Mar Realignment

## REVISED EVALUATION CRITERIA

Evaluation Criteria	Weight (%)
---------------------	------------

<b>Travel Time</b>	<b>14</b>
--------------------	-----------

Environmental Consequences	9
----------------------------	---

ROW Impacts and Acquisitions	6
------------------------------	---

<b>Connectivity and Travel Demand</b>	<b>13</b>
---------------------------------------	-----------

<b>Safety Improvements</b>	<b>15</b>
----------------------------	-----------

Constructability, Construction Impacts, and Duration	7
--	---

Capital Costs (includes construction, right-of-way, and design)	8
---	---

Railroad Operation Impacts (during construction)	5
--	---

Operational Complexity (post-construction)	9
--	---

<b>O&amp;M Costs</b>	<b>10</b>
----------------------	-----------

Community Acceptance	4
----------------------	---

# Del Mar Realignment

## REVISED COMPARATIVE ANALYSIS



Evaluation Criteria	Weight (%)	Camino Del Mar	Crest Canyon			I-5
			Higher Speed	Above Carmel Valley Rd.	Below Carmel Valley Rd.	
Travel Time	14	5	5	5	4	1
Environmental Consequences	9	1	4	4	3	2
ROW Impacts and Acquisitions	6	4	3	1	3	1
Connectivity and Travel Demand	13	3	3	3	3	2
Safety Improvements	15	5	5	5	4	5
Constructability, Construction Impacts, and Duration	7	2	4	1	2	1
Capital Costs (includes construction, right-of-way, and design)	8	5	4	3	2	1
Railroad Operation Impacts (during construction)	5	2	4	4	4	1
Operational Complexity (post-construction)	9	4	4	4	1	4
O&M Costs	10	2	3	3	1	2
Community Acceptance	4	2	3	1	3	1
<b>Total Score</b>		<b>345</b>	<b>396</b>	<b>347</b>	<b>281</b>	<b>223</b>

RATING **5** **4** **3** **2** **1**  
Best ————— Worst

# Del Mar Realignment

## Preliminary Summary



Issue Area	Camino Del Mar	Crest Canyon			I-5
		Higher Speed	Above Carmel Valley Road	Below Carmel Valley Road	
Total Cost	Base	+5%	+5%	+10%	+30%
Total Length (mi)	4.9	4.8	4.5	4.5	5
Tunnel Length (mi)	1.8	2.5	2.5	3.1	2.2
Tunnel Depth (ft)*	35 - 120	35 - 275	35 - 365	35 - 480	35 - 210
Elevated Structure (ft)	8,000	4,800	4,600	130	5,300

\* top of tunnel to existing ground; minimum – maximum depth

# 4 Tunneling and Fire Life Safety (FLS)

# Tunneling and Fire Life Safety

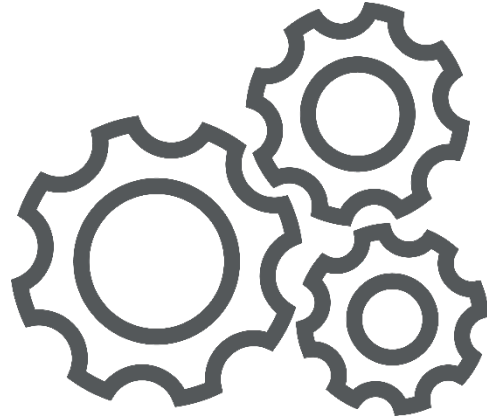

## **TUNNELING CONSIDERATIONS**

- Tunnel Configurations
- Tunnels in Similar Ground Conditions

## **FIRE LIFE SAFETY (FLS) CONSIDERATIONS**

- Egress
- Ventilation

# Tunnel Configurations

SINGLE BORE

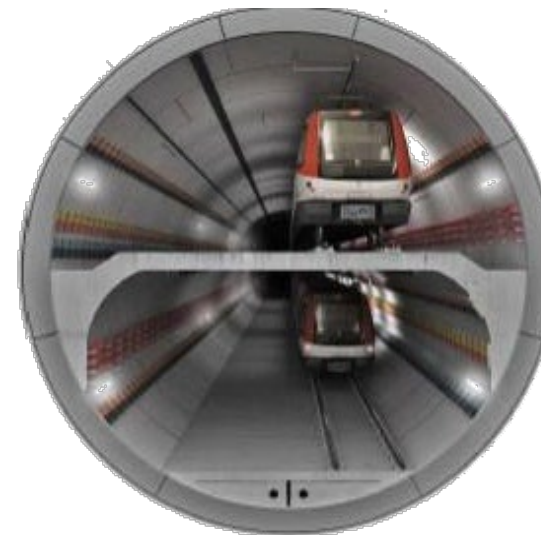
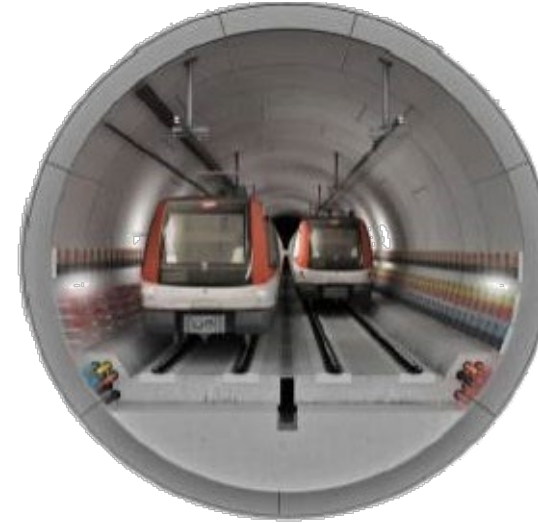
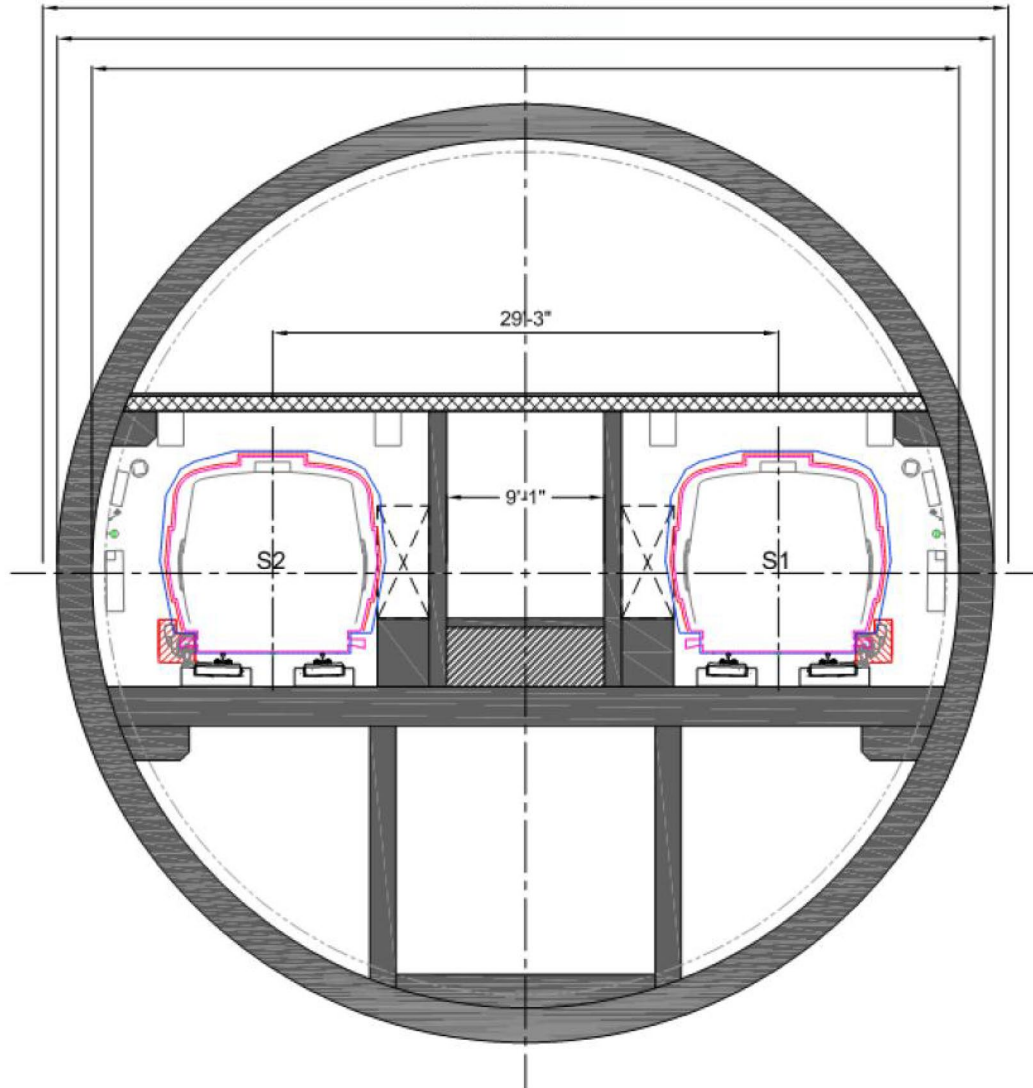

# Tunnel Configurations

TWIN BORE





# Tunnel Configurations

TRIPLE BORE

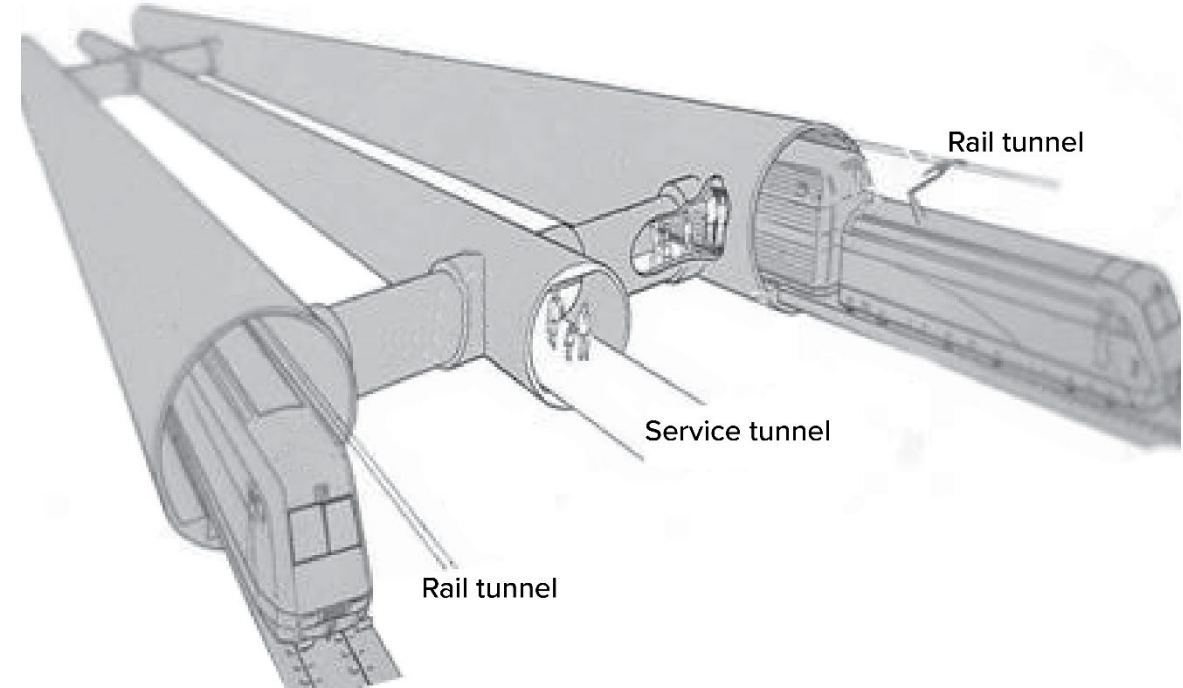
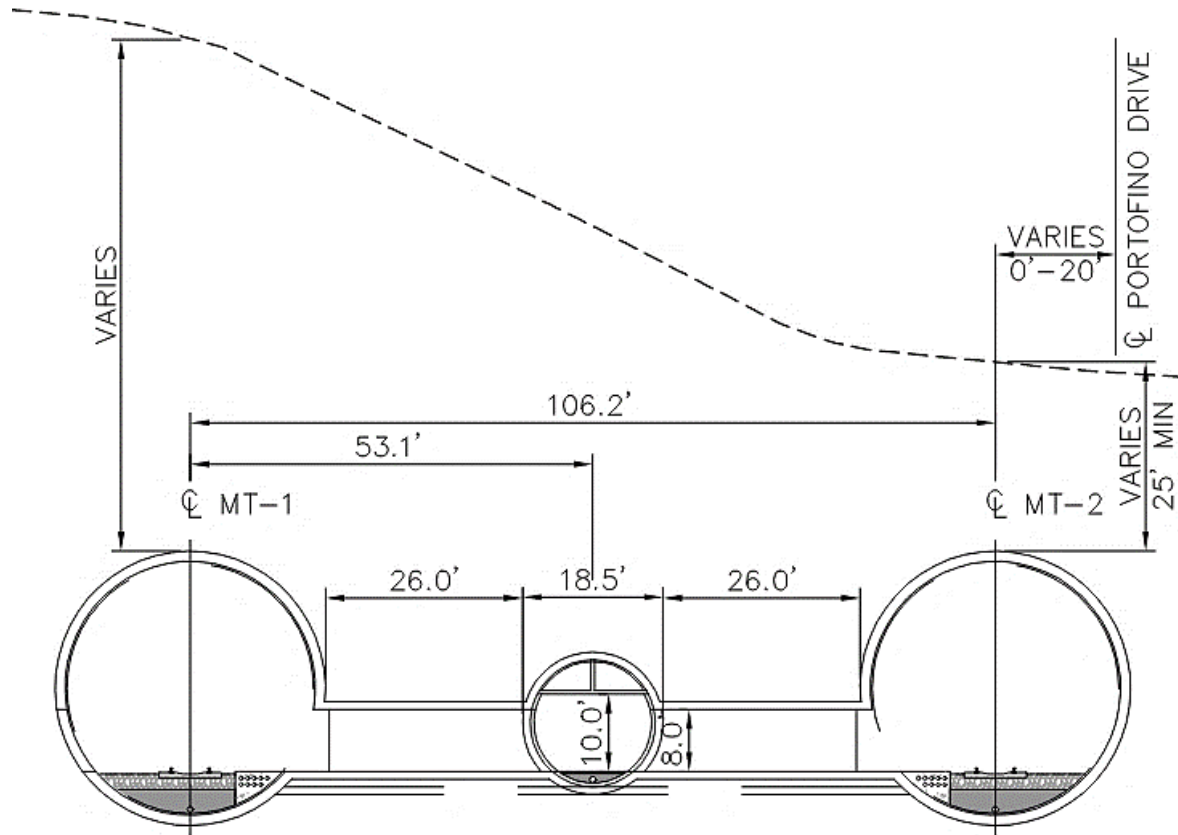

# Tunnels in Similar Ground Conditions



- **Mission Valley East Tunnel** – *San Diego, CA*
- **Courthouse Commons Tunnel** – *San Diego, CA*
- **Regional Connector** – *Los Angeles, CA*
- **Channel Tunnel** – **Between England and France**
- **Alaskan Way Viaduct** – **Seattle, WA**
- **BART to Silicon Valley Phase 2** (design in progress) – **San Jose, CA**

# Tunnels in Similar Ground Conditions



# Fire Life Safety Egress

## REASONS FOR EGRESS

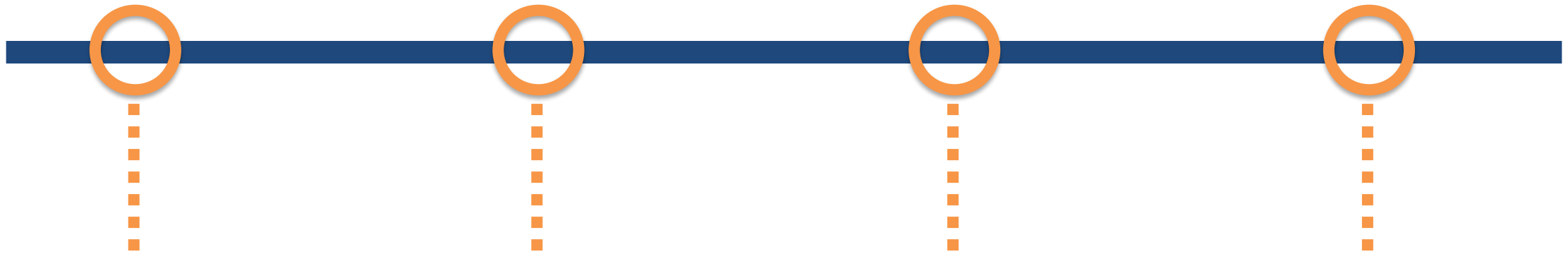

**Escaping from  
a fire on train  
or in tunnel**

**Leaving train  
during power  
outage**

**Derailment**

**Train breakdown**

# Fire Life Safety Egress

## MEANS OF EGRESS

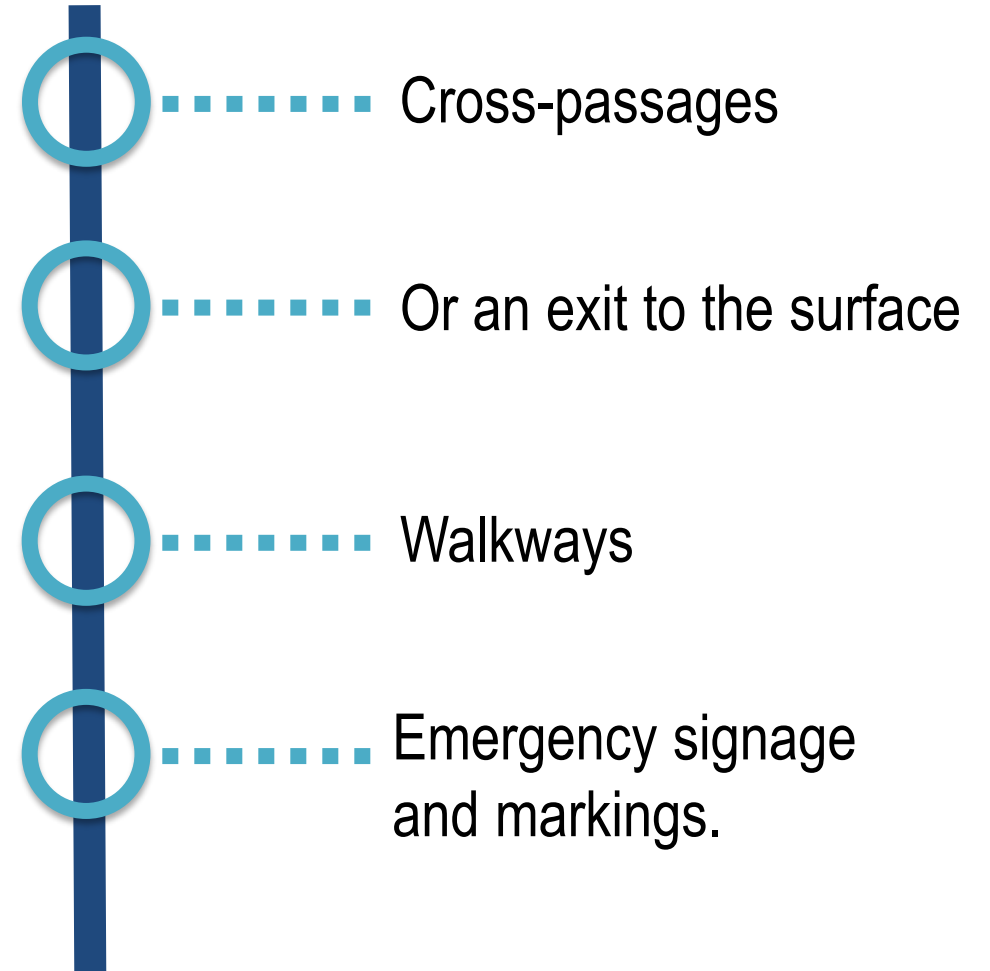

# Need for Ventilation Systems

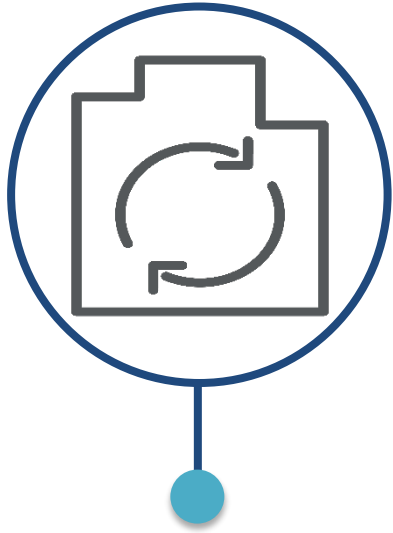

**Acceptable  
temperatures**



**Decrease  
pollutants**

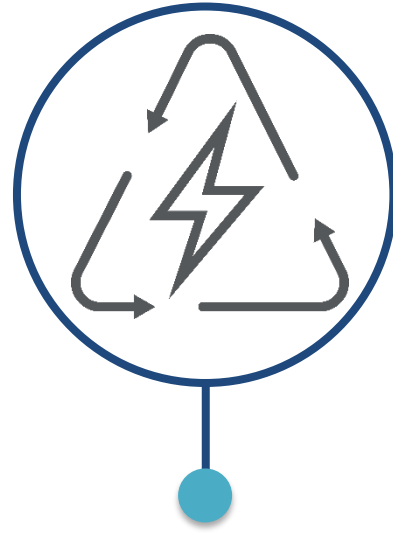

**Control smoke**

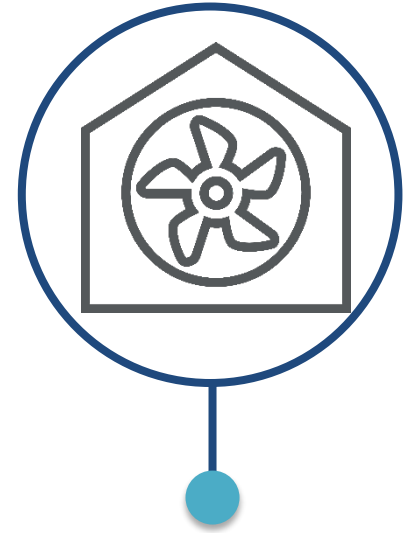

**Code Requirement**

# Ventilation System Components

- Ventilation fans
- Sound attenuators

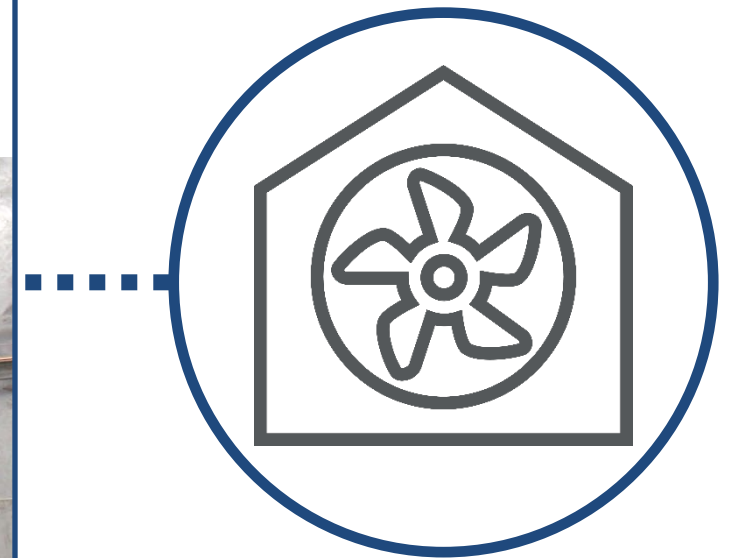

# 5 Operations



# Operations



## TUNNELS WITH SIMILAR OPERATIONS

### O&M FOR RAIL TUNNELS



# Tunnels with Similar Operations



## US Tunnels

- Moffat Tunnel – Colorado
- B&P Tunnel – Maryland
- Cascade Tunnel – Washington
- Flathead Tunnel - Montana

## International Tunnels

- Channel Tunnel – between England and France
- Gotthard Base Tunnel – Switzerland
- Brenner Pass Tunnel – between Austria and Italy (under construction)
- Loetschberg Tunnel - Switzerland

# O&M for Rail Tunnels



## **Key Operations Considerations**

- Operating tunnel lighting
- Operating fans for ventilation
- Operating pumps for track drains

## **Key Maintenance Considerations**

- Water ingress (leaks)
- Checking and maintaining track
- Checking and maintaining train control and systems

# Study Schedule

Baseline Documents*	Del Mar Tunnel Alternatives Analysis	Miramar Hill Tunnel Alternatives Analysis	Corridor Wide Higher Speed Evaluation	Cost Estimates, Phasing and Implementation Plan
Summer 2021	Summer 2021	Fall 2021	Fall 2021	Spring 2022
Public Outreach				

*\*Baseline Documents are Existing Conditions, Higher Speed Operational Feasibility, Track and Tunnel Basis of Design, Corridor Resiliency*

Study to conclude in April 2022

Future phases of development are pending funding