



SAN DIEGO ASSOCIATION OF GOVERNMENTS

# BORDER TO BAYSHORE BIKEWAY TRAFFIC & SAFETY IMPACT ASSESSMENT

## *APPENDIX A: DRAFT CONCEPT PLANS*

FINAL  
OCTOBER 29, 2018





## **APPENDICES**

- A DRAFT CONCEPT PLANS**
- B EXISTING LEVEL OF TRAFFIC STRESS**
- C TRAFFIC COUNTS**
- D FUTURE-YEAR TRAFFIC VOLUMES**
- E SIGNAL TIMING PLANS**
- F ROADWAY NETWORK DESCRIPTION**
- G INTERSECTION ANALYSIS RESULTS**

# APPENDIX

# A DRAFT CONCEPT PLANS

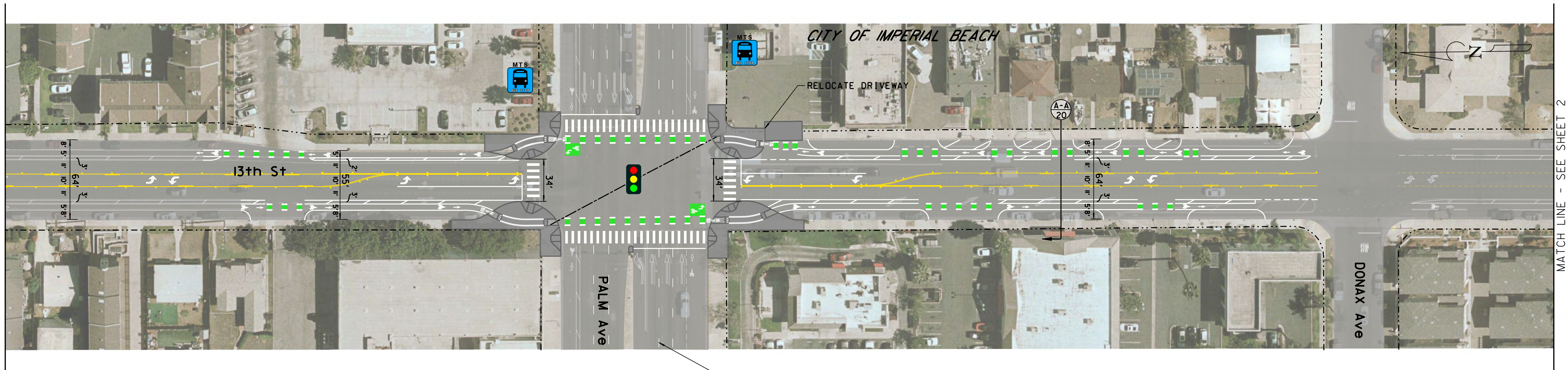
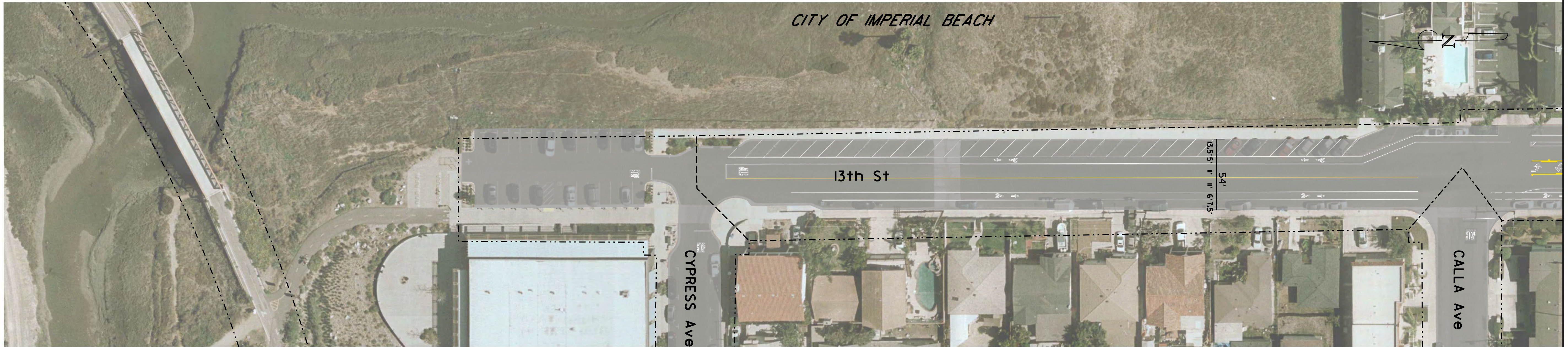

MATCH LINE - SEE ABOVE

MATCH LINE - SEE BELOW

MATCH LINE - SEE SHEET 2

# BORDER TO BAYSHORE BIKEWAY

OCTOBER 2018

CONCEPTUAL SHEETS

SHEET 01 OF 25



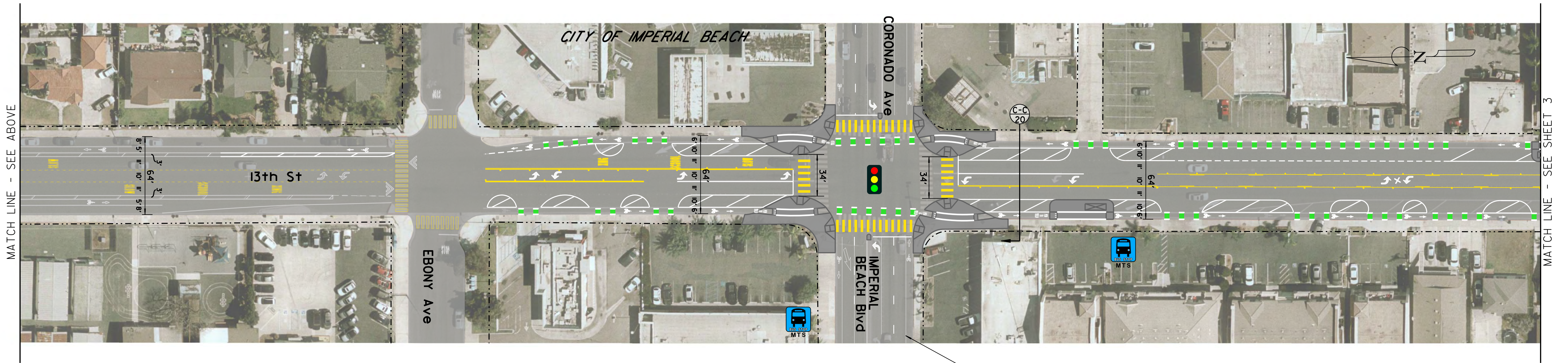
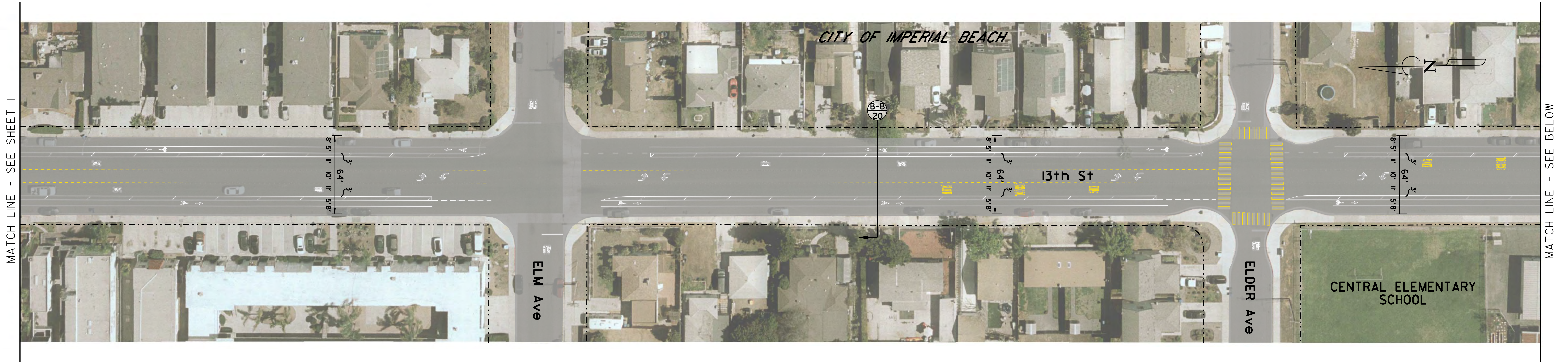

# BORDER TO BAYSHORE BIKEWAY

OCTOBER 2018

CONCEPTUAL SHEETS

SHEET 02 OF 25



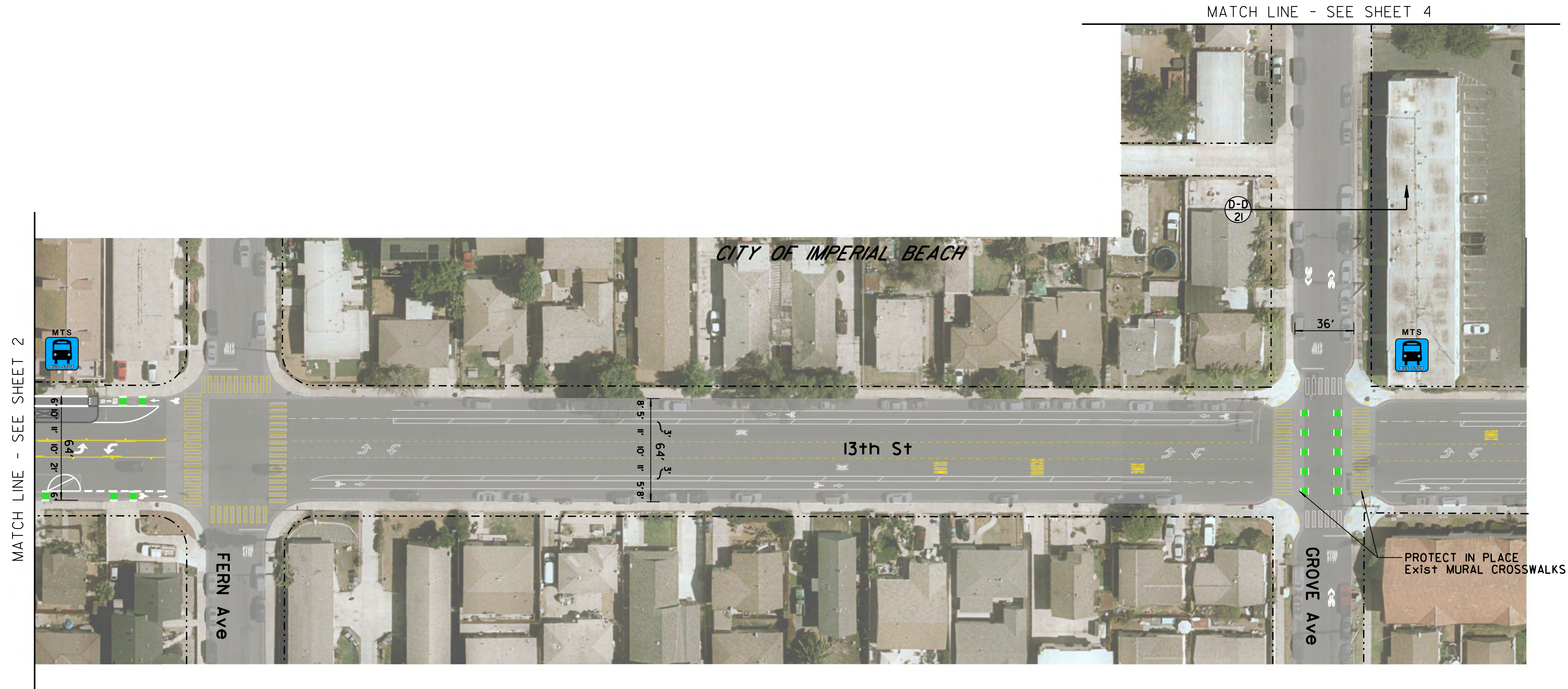
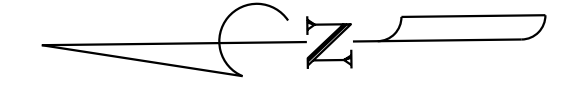

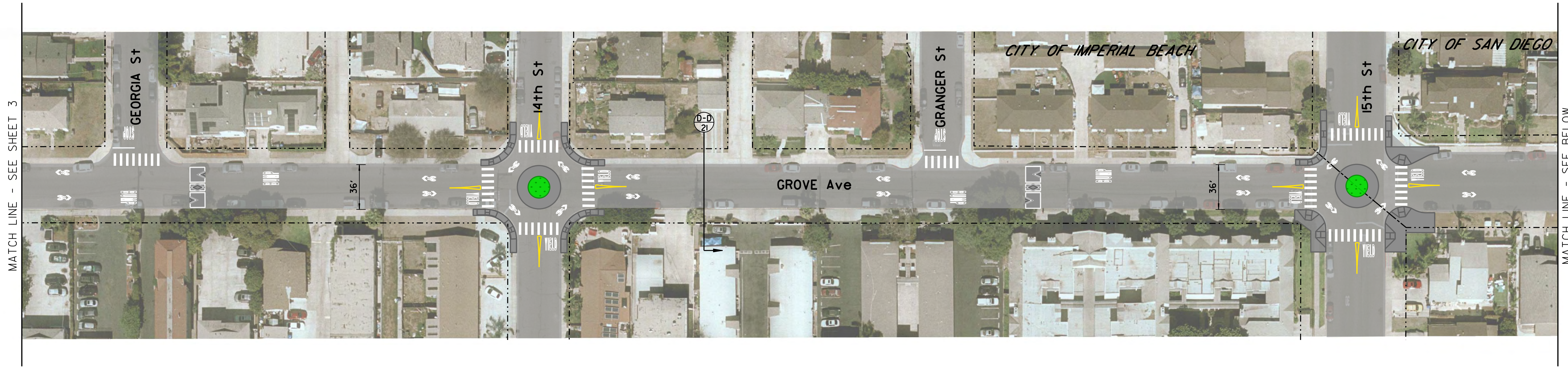

# BORDER TO BAYSHORE BIKEWAY

OCTOBER 2018

CONCEPTUAL SHEETS

SHEET 04 OF 25



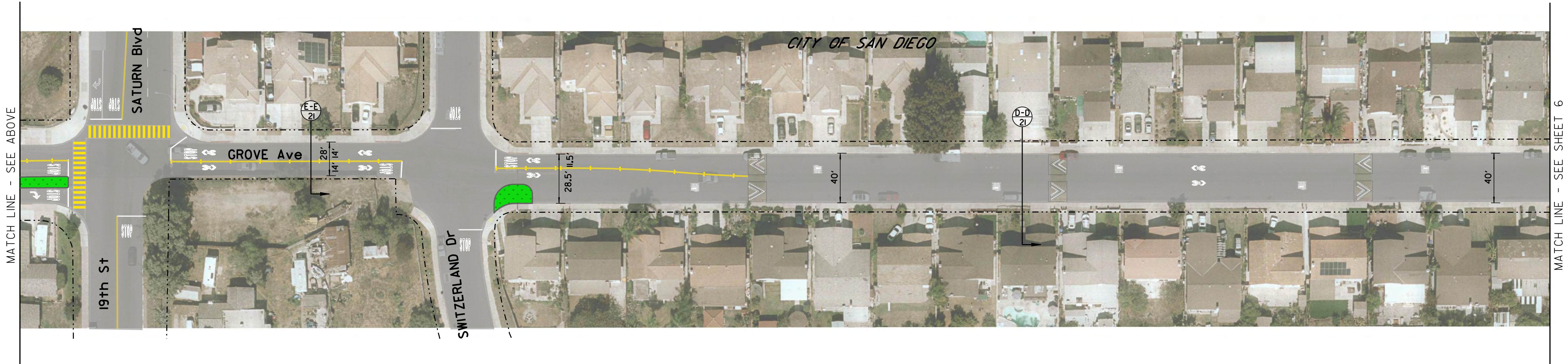

# BORDER TO BAYSHORE BIKEWAY

OCTOBER 2018

CONCEPTUAL SHEETS

SHEET 05 OF 25





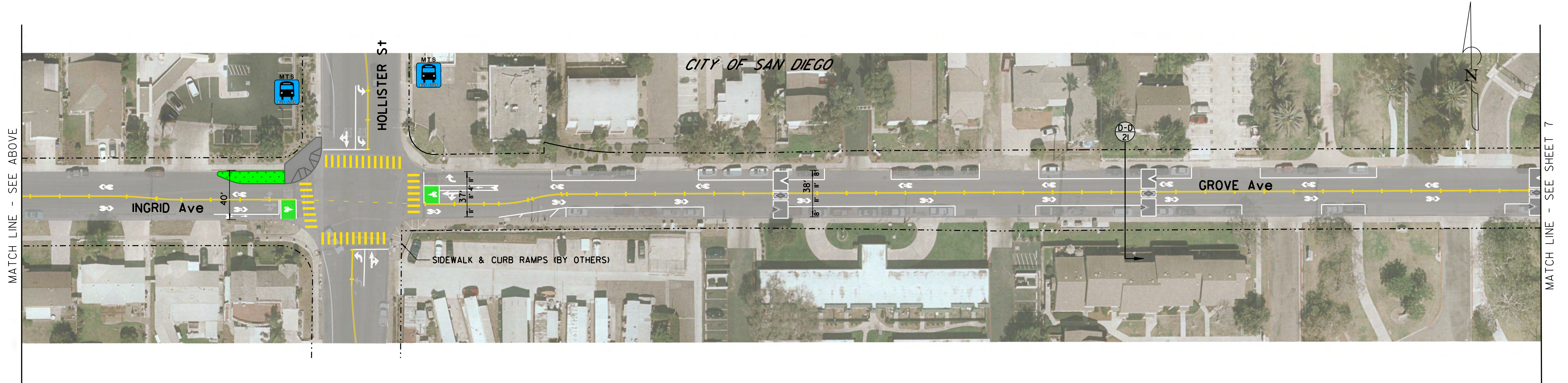

# BORDER TO BAYSHORE BIKEWAY

OCTOBER 2018

CONCEPTUAL SHEETS

SHEET 06 OF 25



WALKWAY

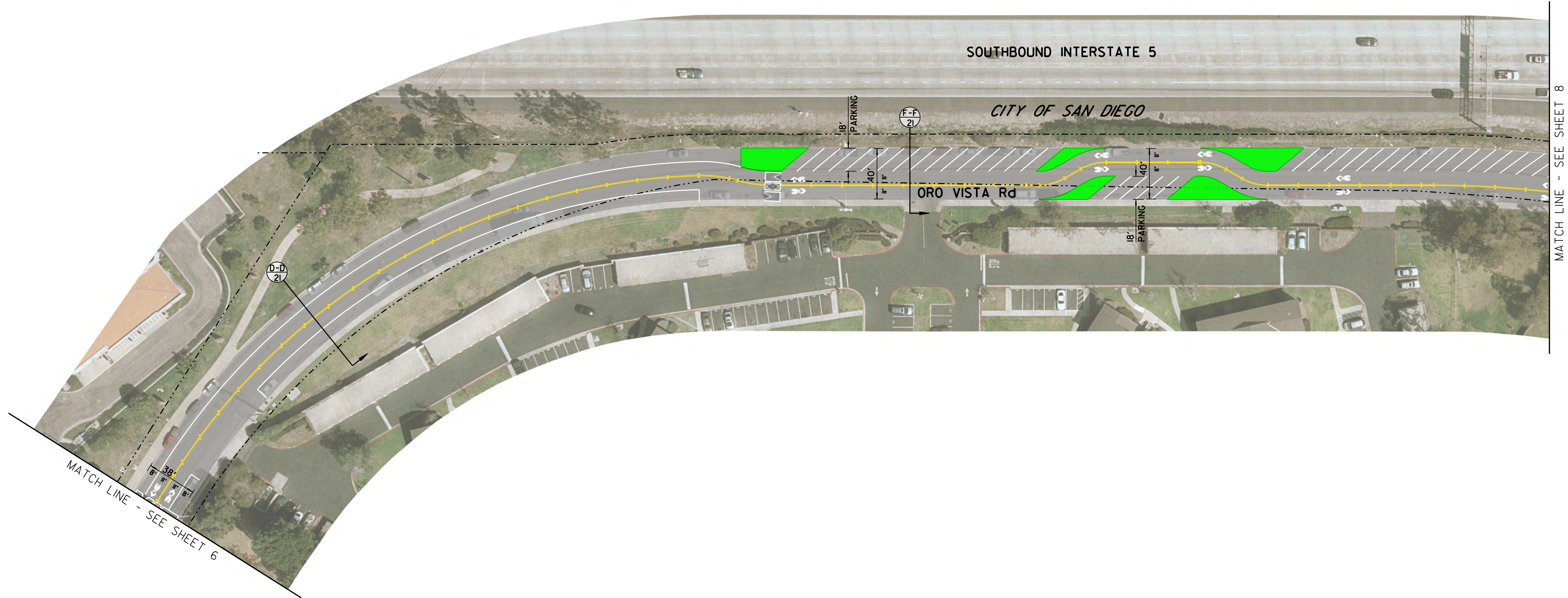
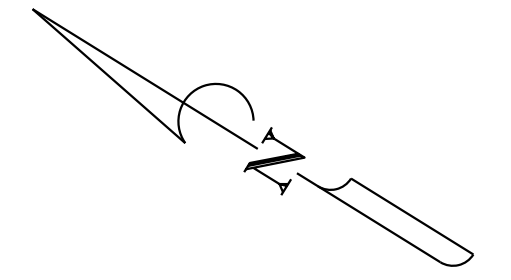

# BORDER TO BAYSHORE BIKEWAY

OCTOBER 2018

CONCEPTUAL SHEETS

SHEET 07 OF 25



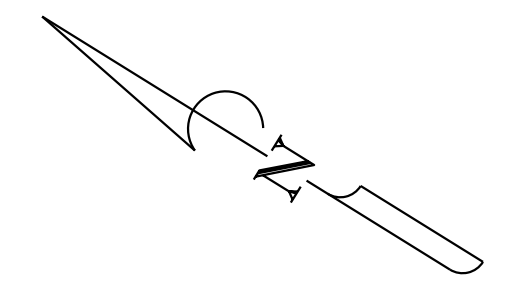

# BORDER TO BAYSHORE BIKEWAY

OCTOBER 2018

CONCEPTUAL SHEETS

SHEET 08 OF 25



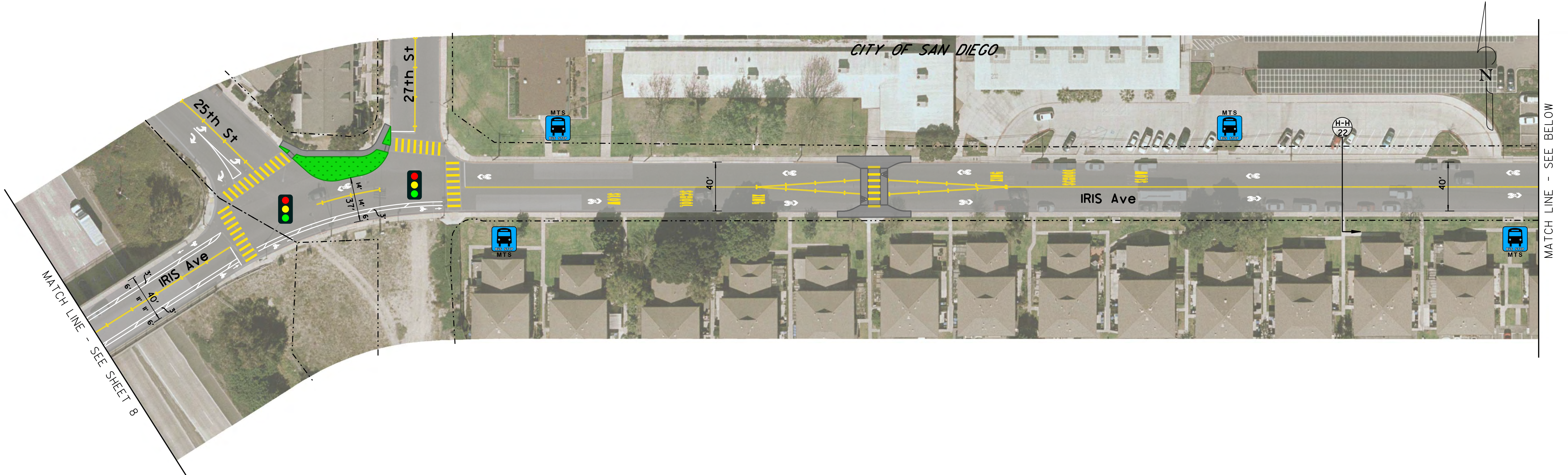

# BORDER TO BAYSHORE BIKEWAY

OCTOBER 2018

CONCEPTUAL SHEETS

SHEET 09 OF 25



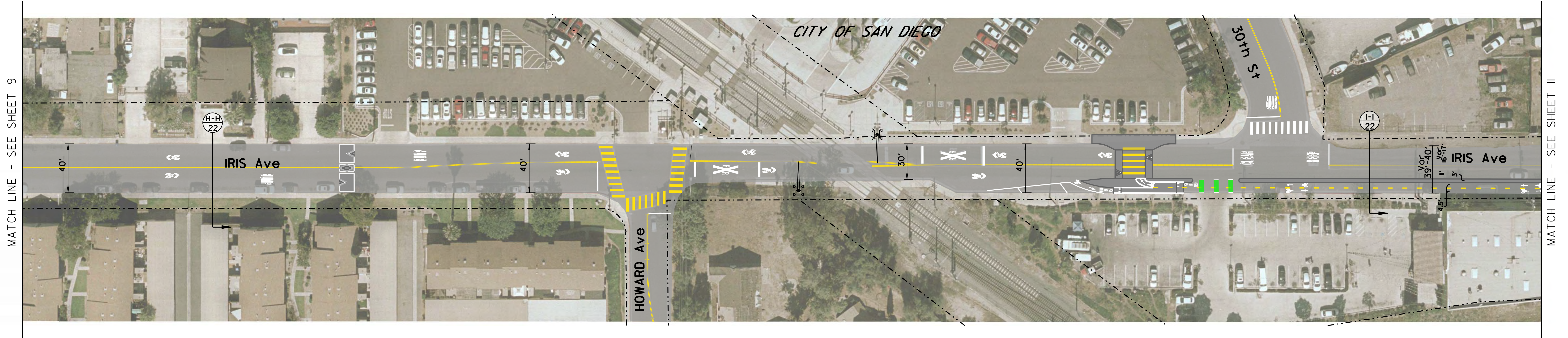

# BORDER TO BAYSHORE BIKEWAY

OCTOBER 2018

CONCEPTUAL SHEETS

SHEET 10 OF 25



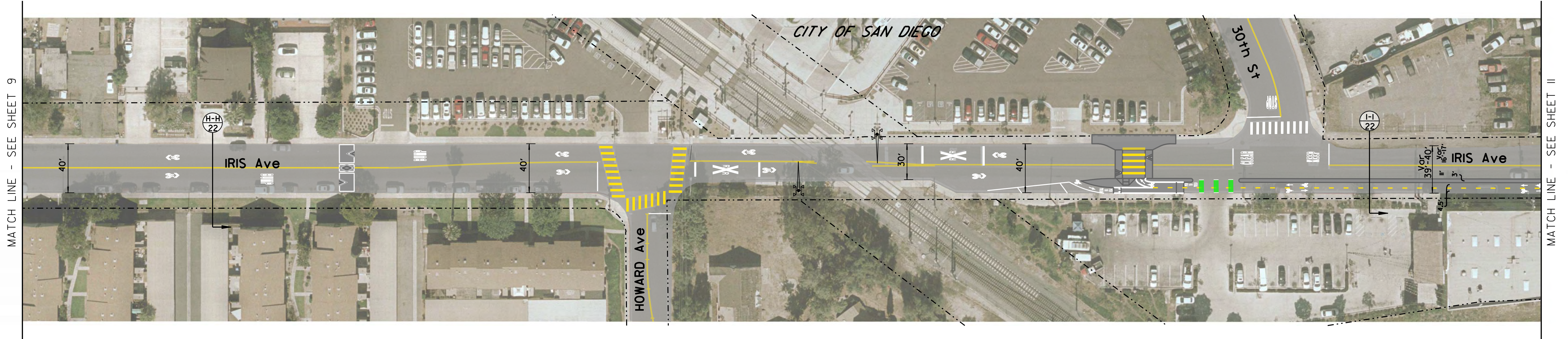

# BORDER TO BAYSHORE BIKEWAY

OCTOBER 2018

CONCEPTUAL SHEETS

SHEET 10 OF 25



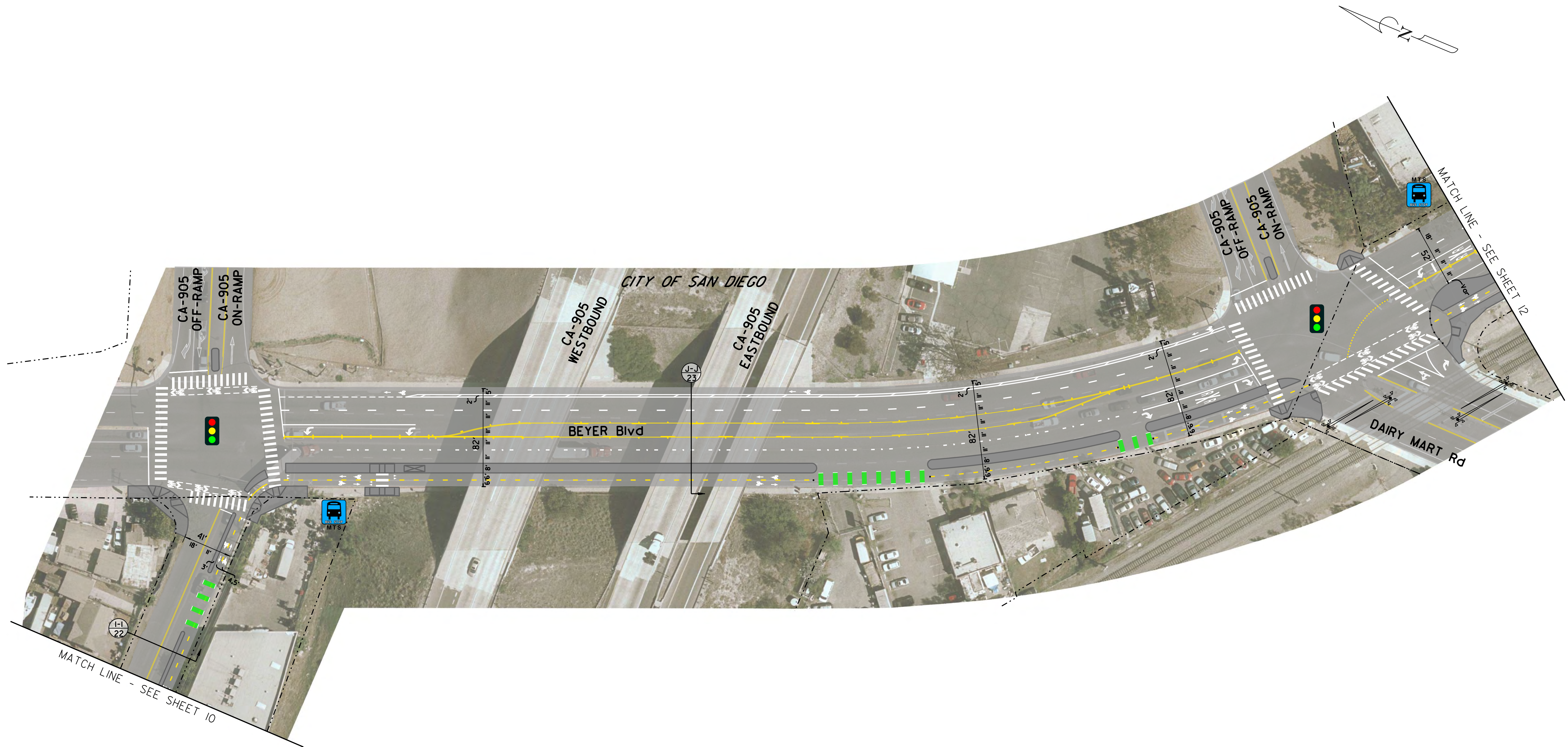

# BORDER TO BAYSHORE BIKEWAY

OCTOBER 2018

CONCEPTUAL SHEETS

SHEET 11 OF 25



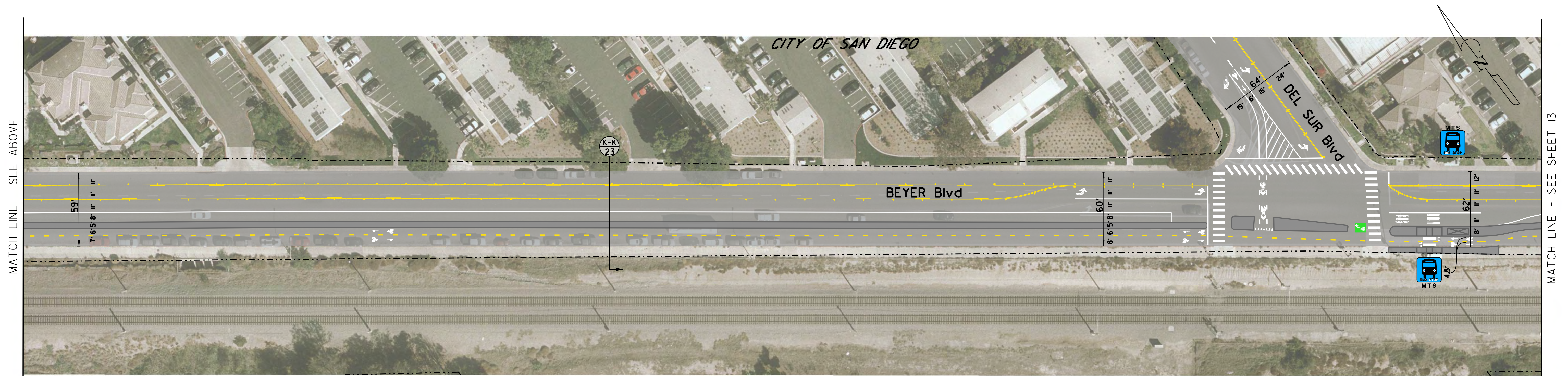
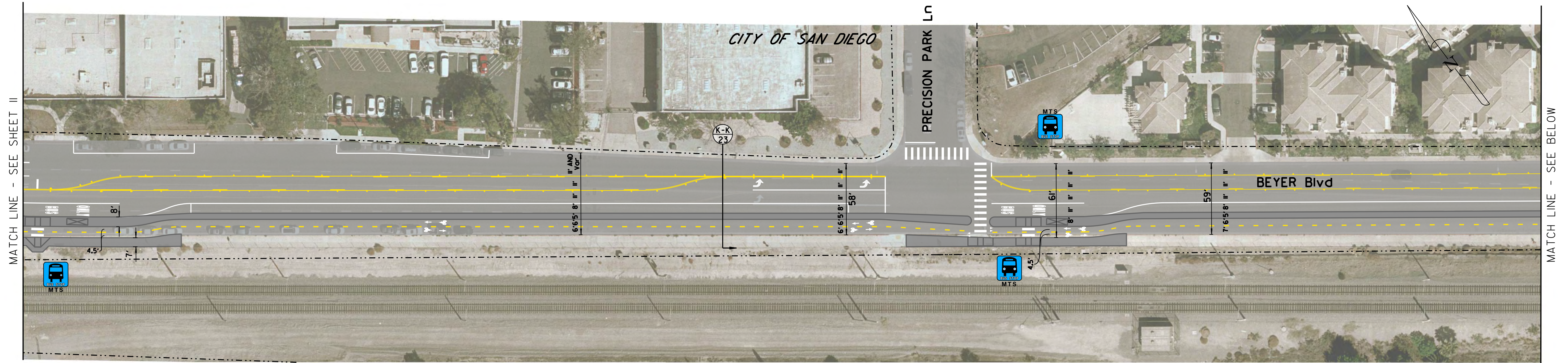

# BORDER TO BAYSHORE BIKEWAY

OCTOBER 2018

CONCEPTUAL SHEETS

SHEET 12 OF 25





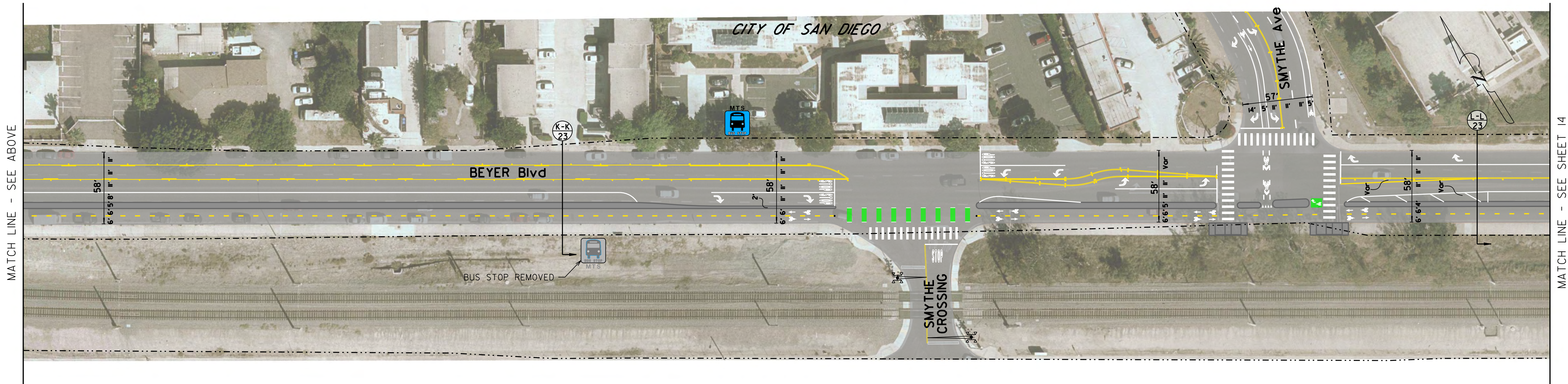
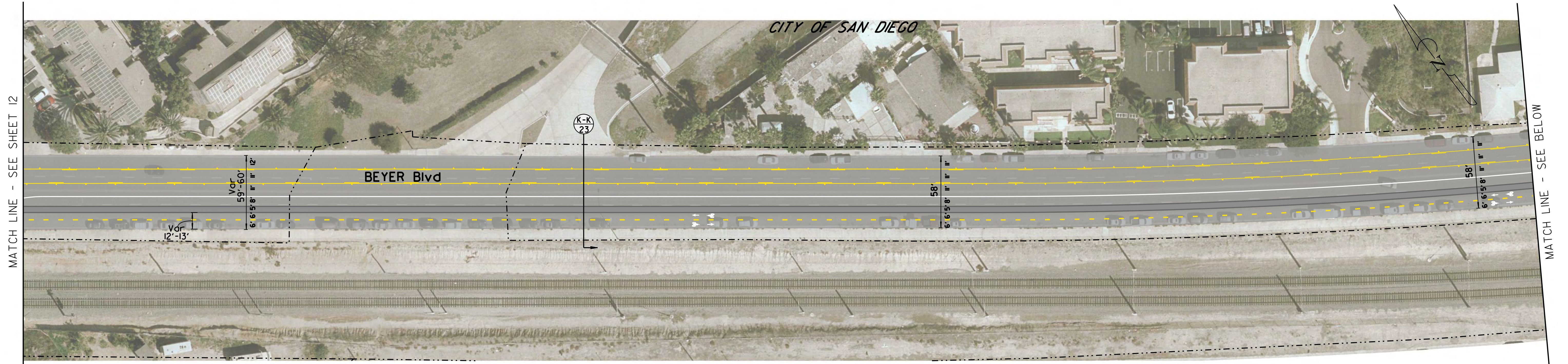

# BORDER TO BAYSHORE BIKEWAY

OCTOBER 2018

CONCEPTUAL SHEETS

SHEET 13 OF 25





# BORDER TO BAYSHORE BIKEWAY

OCTOBER 2018

CONCEPTUAL SHEETS

SHEET 14 OF 25



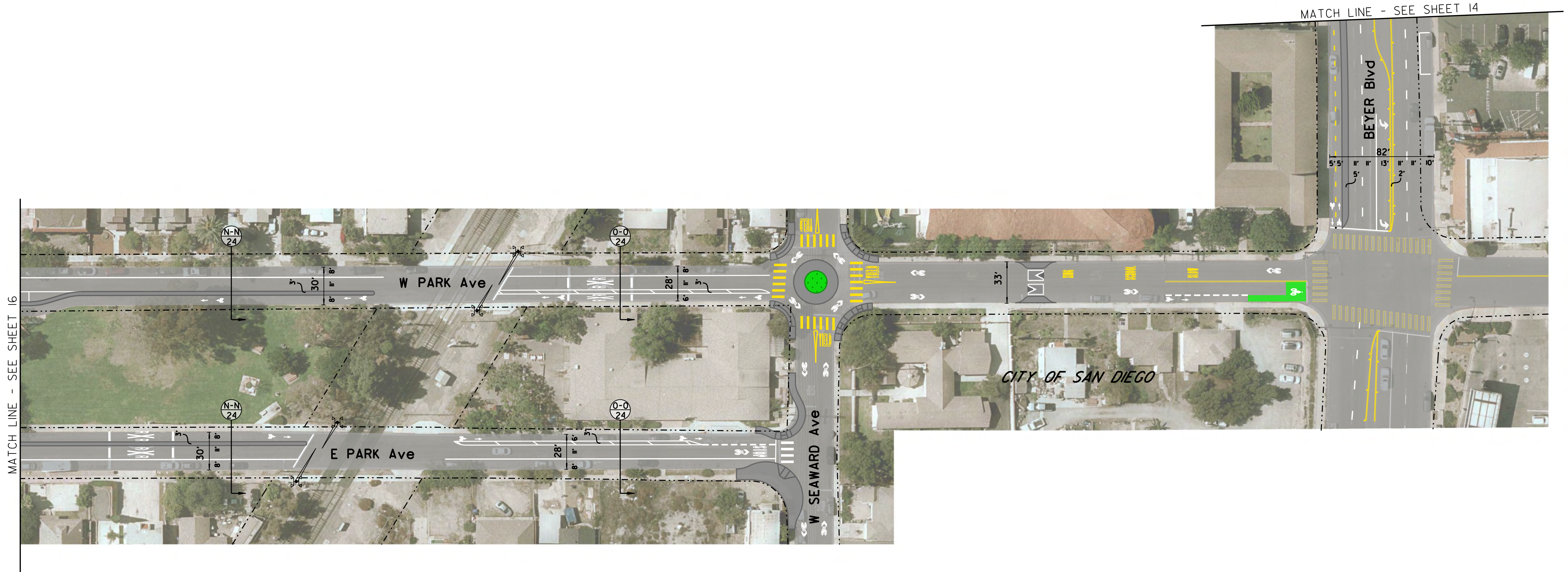

MATCH LINE - SEE SHEET 16

MATCH LINE - SEE SHEET 14

CITY OF SAN DIEGO

# BORDER TO BAYSHORE BIKEWAY

OCTOBER 2018

CONCEPTUAL SHEETS

SHEET 15 OF 25

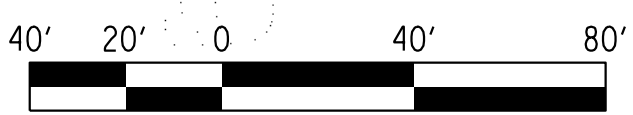

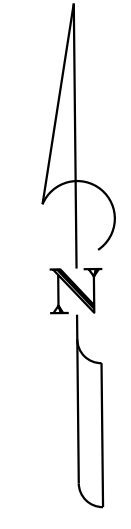

# BORDER TO BAYSHORE BIKEWAY

OCTOBER 2018

CONCEPTUAL SHEETS

SHEET 16 OF 25



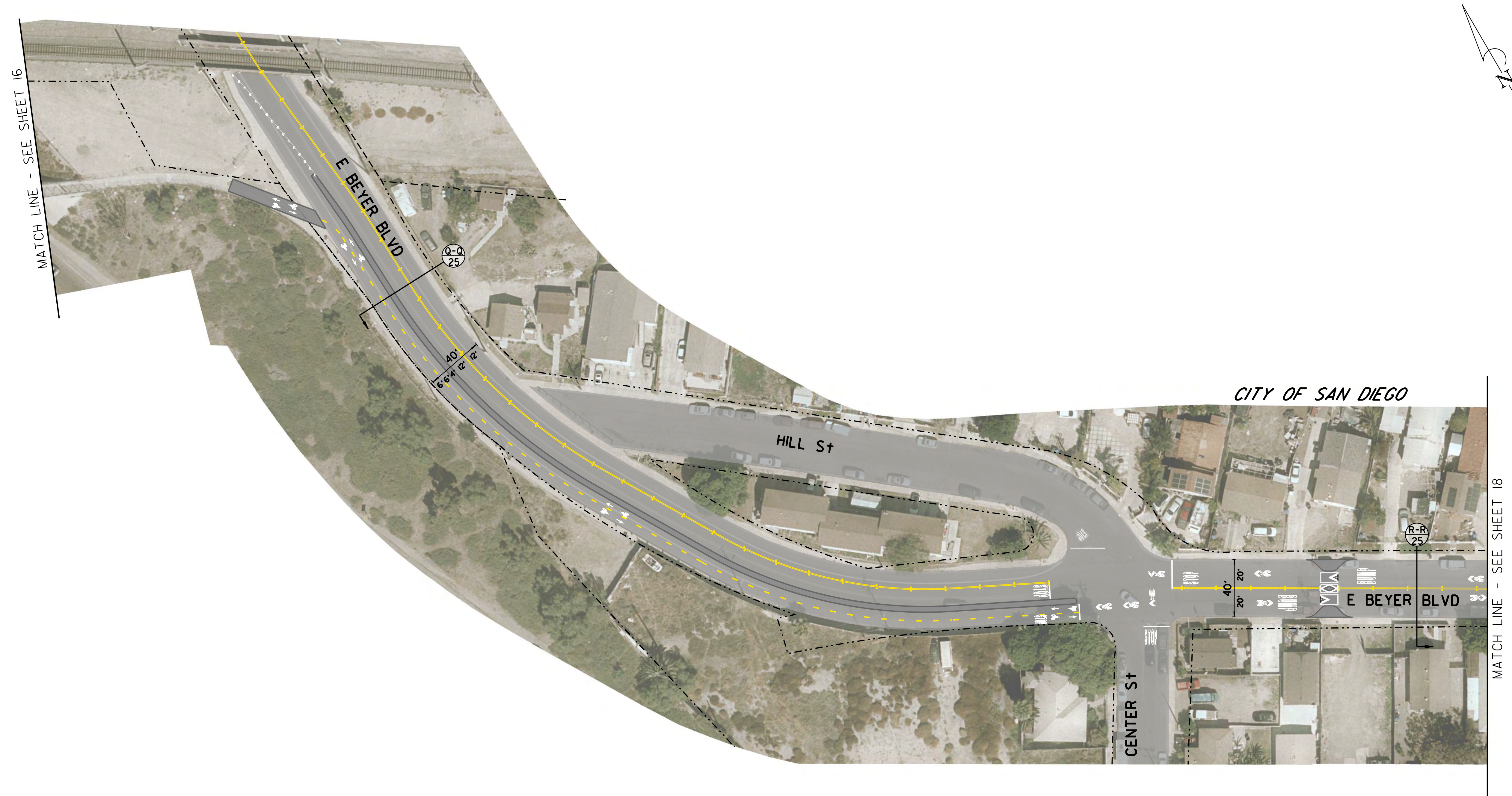

# BORDER TO BAYSHORE BIKEWAY

OCTOBER 2018

CONCEPTUAL SHEETS

SHEET 17 OF 25



CITY OF SAN DIEGO

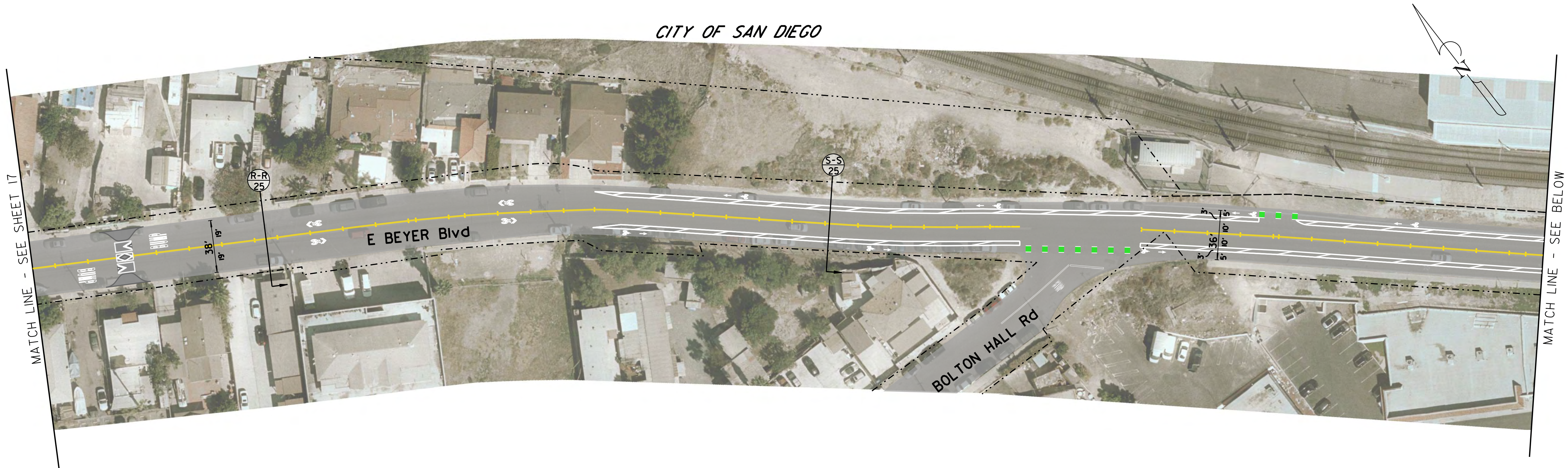

CITY OF SAN DIEGO

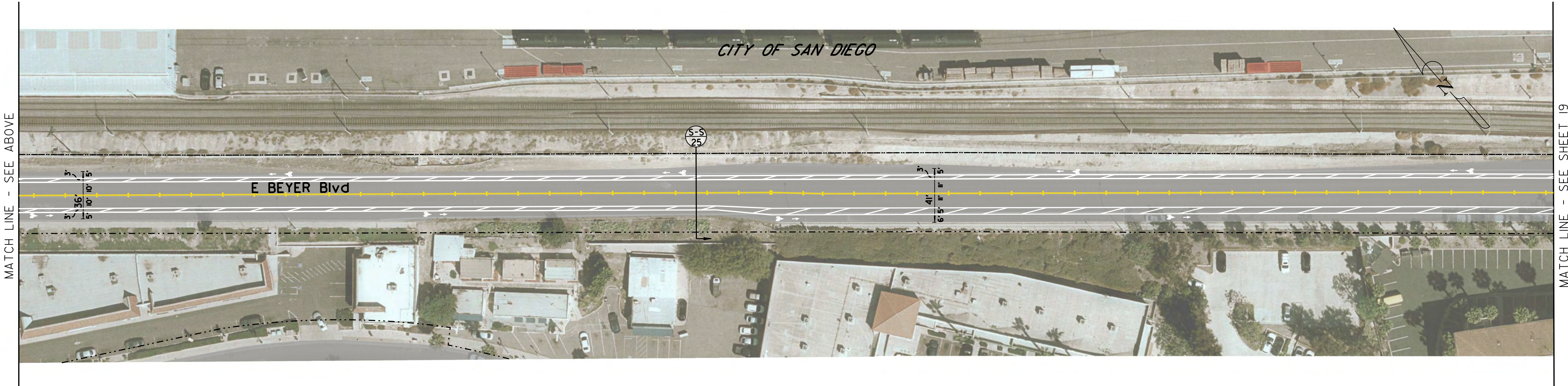

# BORDER TO BAYSHORE BIKEWAY

OCTOBER 2018

CONCEPTUAL SHEETS

SHEET 18 OF 25



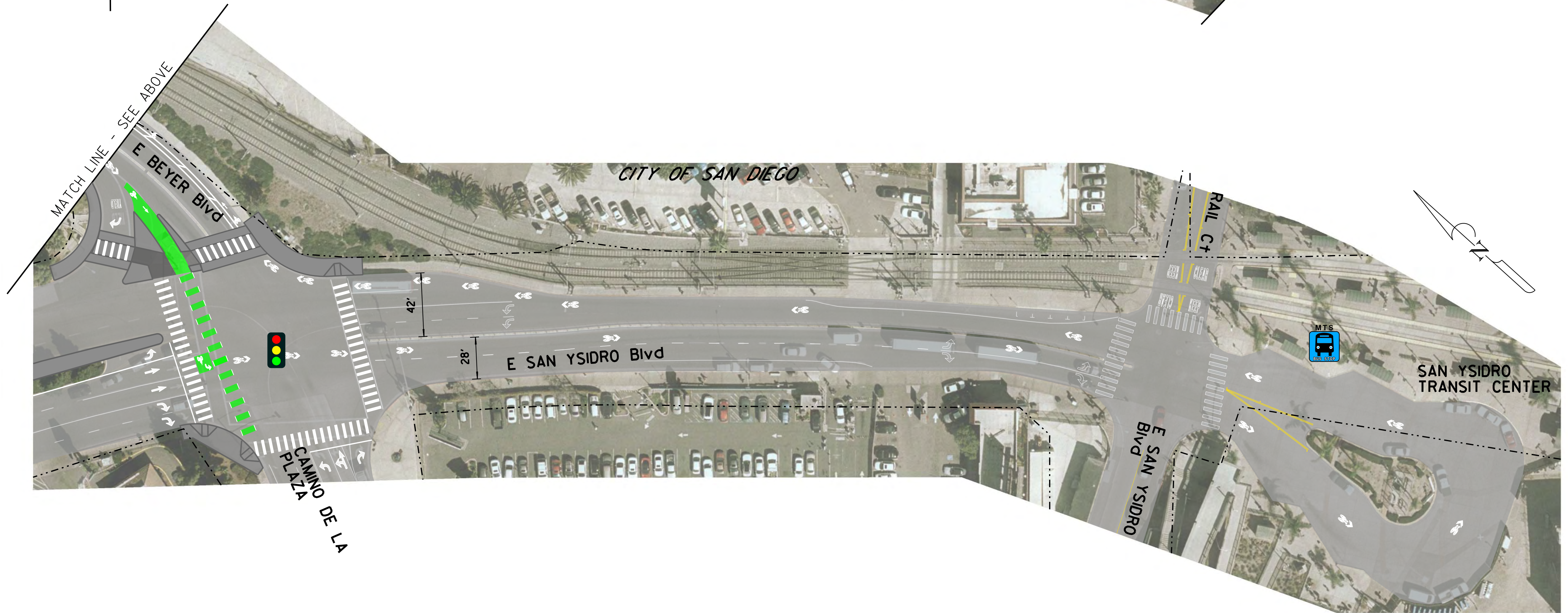

# BORDER TO BAYSHORE BIKEWAY

OCTOBER 2018

CONCEPTUAL SHEETS

SHEET 19 OF 25



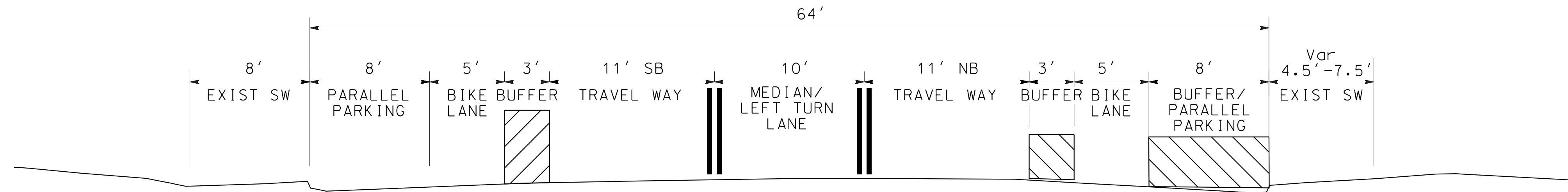

A-A: PROPOSED BIKEWAY ON 13TH ST (CLASS II)  
PALM Ave TO DONAX Ave

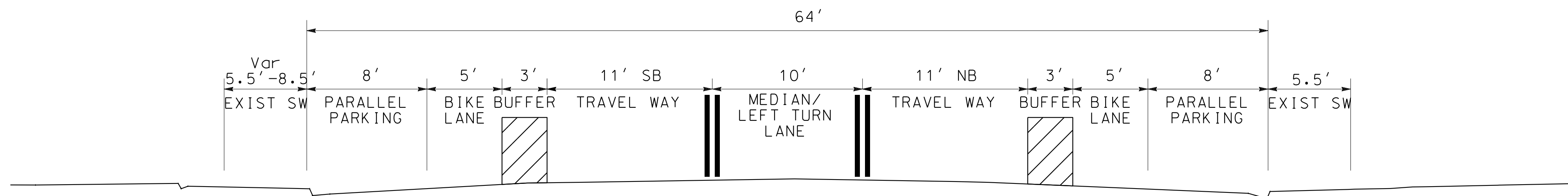

B-B: PROPOSED BIKEWAY ON 13th St (CLASS II)  
DONAX Ave TO EBONY Ave  
FERN Ave TO GROVE Ave

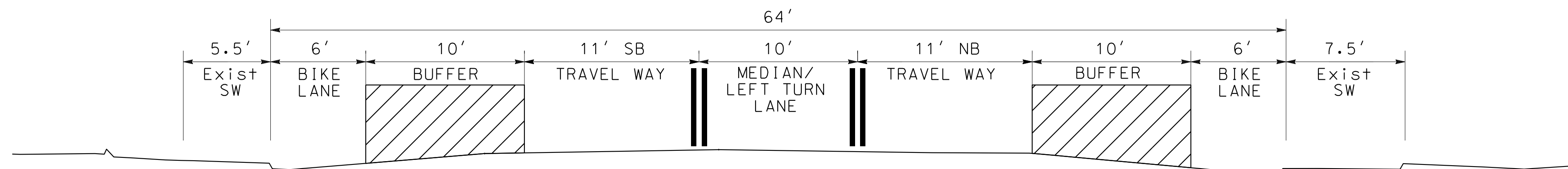

C-C: PROPOSED BIKEWAY ON 13TH ST (CLASS II)  
EBONY Ave TO FERN Ave



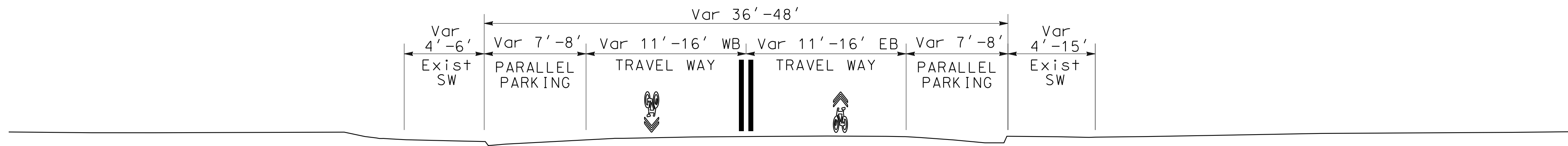

D-D: PROPOSED BIKEWAY ON GROVE AVE (CLASS III)  
13th St TO WEST OF SATURN Blvd  
SWITZERLAND Dr TO ORO VISTA Rd

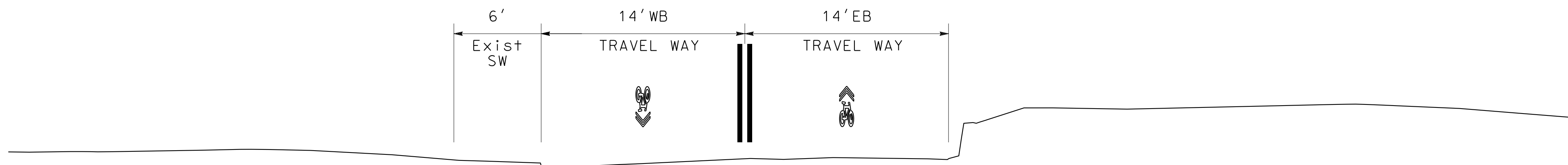

E-E: PROPOSED BIKEWAY ON GROVE AVE (CLASS III)  
SATURN BLVD TO SWITZERLAND DR

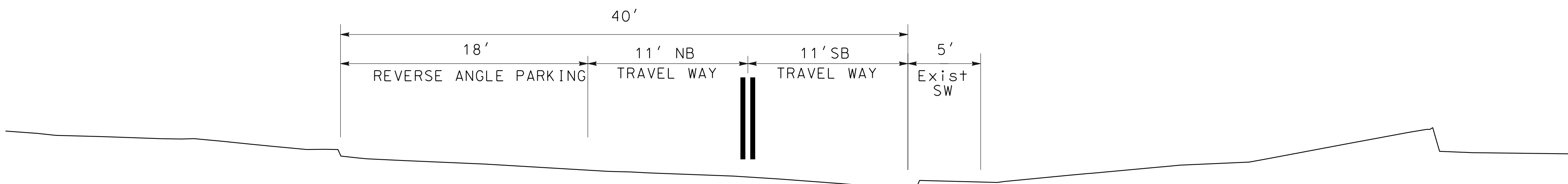

F-F: PROPOSED BIKEWAY ON ORO VISTA RD (CLASS III)

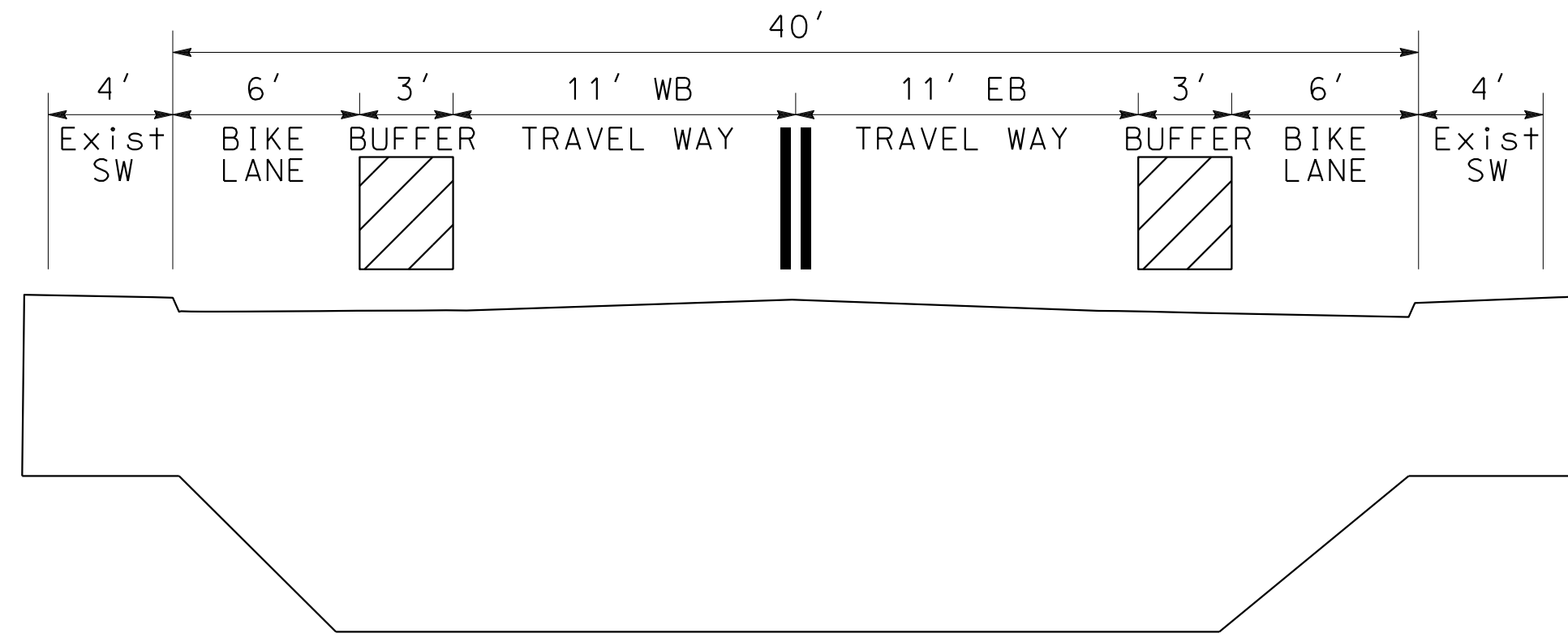

G-G: PROPOSED BIKEWAY ON IRIS AVE (CLASS II)  
EXISTING BRIDGE OVER FREEWAY

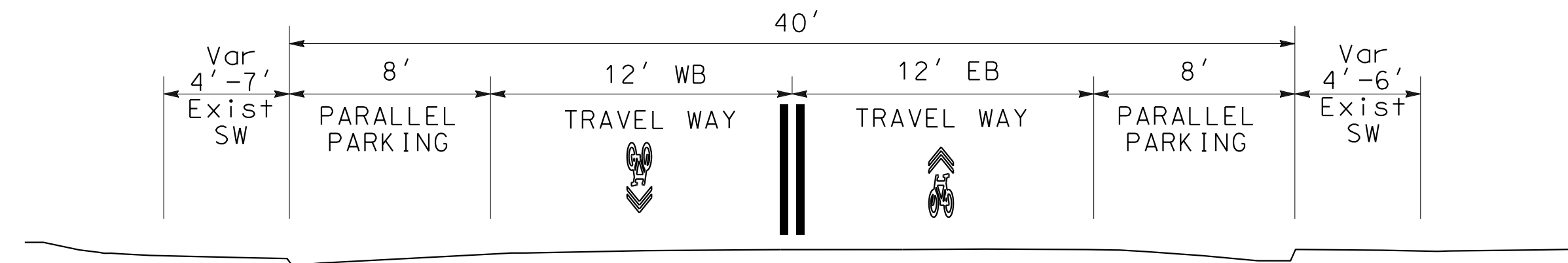

H-H: PROPOSED BIKEWAY ON IRIS AVE (CLASS III)  
27th St TO HOWARD Ave

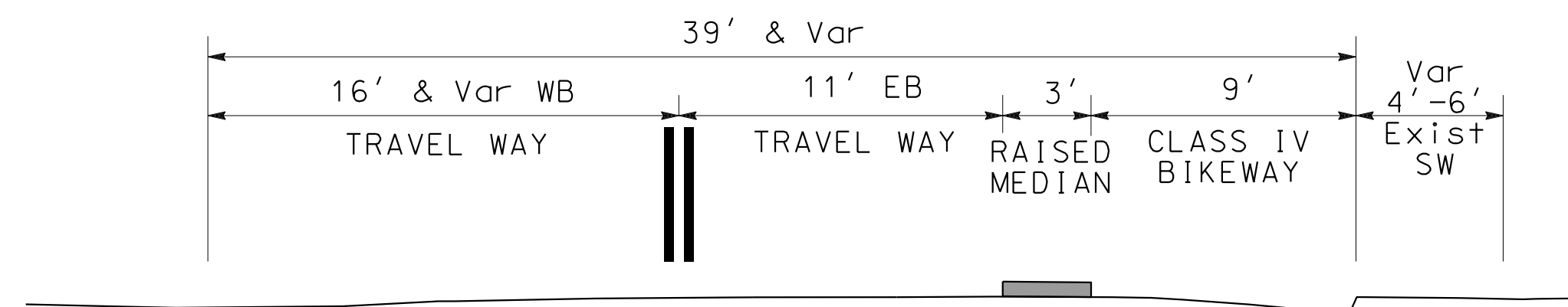

I-I: PROPOSED BIKEWAY ON IRIS AVE (CLASS IV)  
WEST OF 30th St TO BEYER Blvd

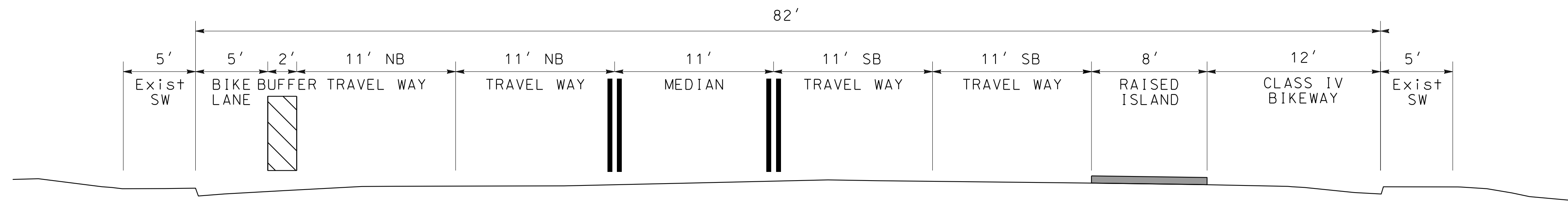

J-J: PROPOSED BIKEWAY ON BEYER BLVD (CLASS II & IV)  
IRIS AVE TO DAIRY MART RD

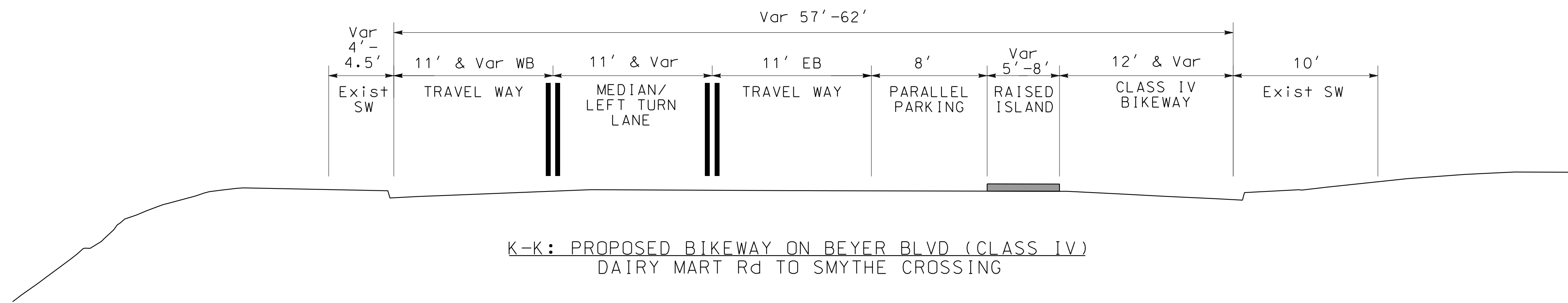

K-K: PROPOSED BIKEWAY ON BEYER BLVD (CLASS IV)  
DAIRY MART RD TO SMYTHE CROSSING

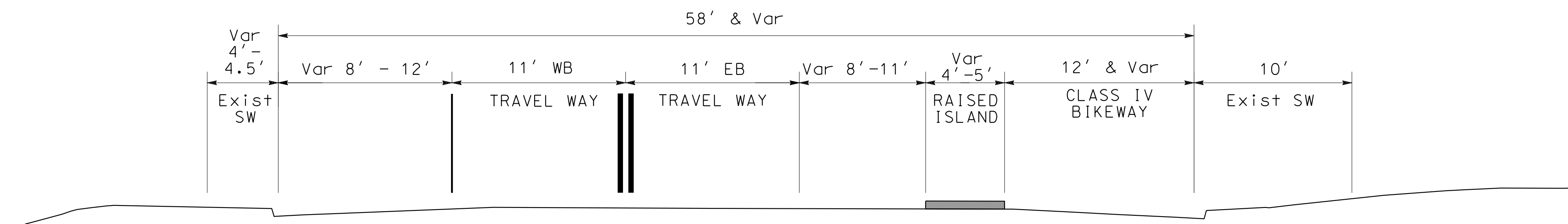

L-L: PROPOSED BIKEWAY ON BEYER BLVD (CLASS IV)  
SMYTHE CROSSING TO COTTONWOOD RD

